

MDH Tie-rod mold cylinder with limit switches

MDH

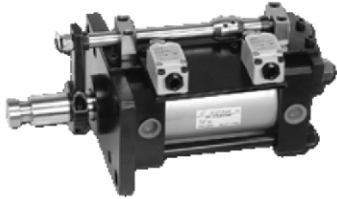

Features

- MDH model is a heavy duty tie-rod cylinder with limit switches which are used to control precisely the position of molds.
- MDH model is especially suitable for die-casting molding machines.

Theoretical output force

bore(mm)		32	40	50	63	80	100	125	150		
pressed area (cm ²)	push(cm ²)	8	12.6	19.6	31.2	50.3	78.5	122.7	176.7		
	pull(cm ²)	rod	C	6	9.4	14.7	24.1	40.6	66	98.1	141.5
			B	4.9	7.7	12.6	21.6	38	53.9	83.1	120
output force(kgs)	pressure (70 kgf/cm ²)	push	560	880	1375	2182	3519	5498	8590	12370	
		lind	C	420	660	1301	1687	2838	4618	6867	9902
			B	343	536	880	1508	2660	3774	5819	8398
	pressure (140 kgf/cm ²)	push	1120	1760	2750	4343	7038	10995	17181	24741	
		lind	C	840	1320	2062	3374	5676	9236	13734	19804
			B	686	1072	1760	3016	5320	7548	11638	16796
	pressure (210 kgf/cm ²)	push	1680	2646	4116	6552	10563	16485	25767	37107	
		lind	C	1260	1974	3087	5061	8526	13860	20601	29715
			B	1029	1617	2646	4536	7980	11319	17451	25200

MDH Tie-rod mold cylinders
MDC Compact mold cylinders

note : application of the MDH Tie-rod mold cylinders especially utilizes the "pull" output force.

GENTLE AUTOMATIC SOLUTION SDN BHD

No.36, Jalan Industri USJ 1/13, Taman Perindustrian USJ 1, 47600 Subang Jaya, Selangor.

TEL: 603-8023 7743 / 8743 FAX: 603-8023 9743

email:sales@gentle.com.my

Internal structure and part names

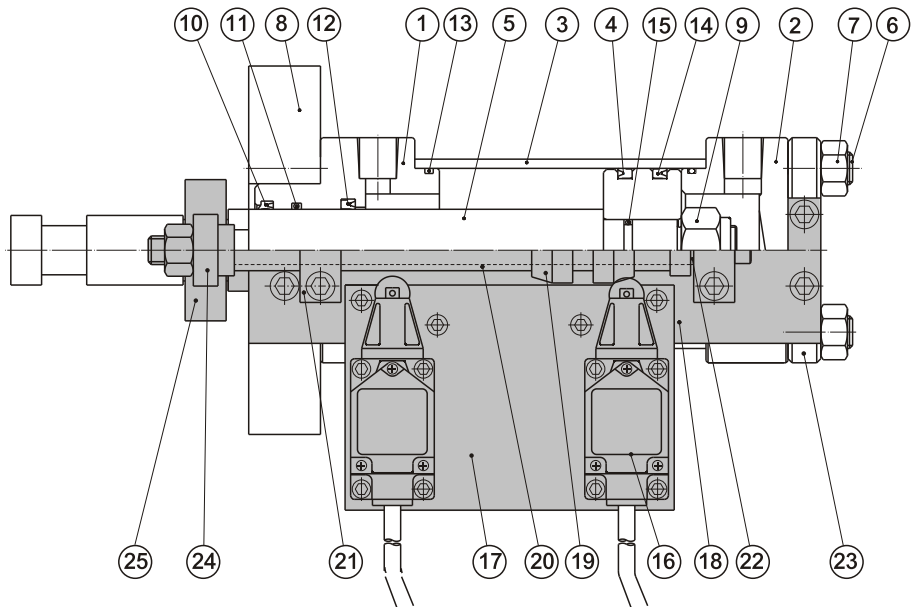

MDH Tie-rod mold cylinders
MDC Compact mold cylinders

item	part name	q'ty	item	part name	q'ty
①	rod cover	1	⑭	piston seal	2
②	head cover	1	⑮	piston o-ring	1
③	tube	1	⑯	limit switch	2
④	piston	1	⑰	l.s. mounting plate	1
⑤	rod	1	⑱	touch block	2
⑥	tie-rod	4	⑳	touch rod	1
⑦	tie-rod nut	4	㉑	mounting socket	2
⑧	flange	1	㉒	support rod	1
⑨	piston nut	1	㉓	holding plate	1
⑩	dust seal	1	㉔	rod connector	1
⑪	rod o-ring	1	㉕	connecting plate	1
⑫	rod seal	1			
⑬	cover o-ring	2			

GENTLE AUTOMATIC SOLUTION SDN BHD

No.36, Jalan Industri USJ 1/13, Taman Perindustrian USJ 1, 47600 Subang Jaya, Selangor.

TEL: 603-8023 7743 / 8743 FAX: 603-8023 9743

email:sales@gentle.com.my

Seal spec.

bore	name q'ty	⑩	⑪	⑫	⑬	⑭	⑮
		dust seal (PU)	rod o-ring (IB)	rod seal (PU)	cover o-ring (IB)	piston seal (PU)	piston o-ring (IA)
		1	1	1	2	2	1
40	C	DH20	P20	UHS20	G35	UHS30	P10A
	B	DH25	P25	UHS25			
50	C	DH25	P25	UHS25	G45	UHS40	P16
	B	DH30	P30	UHS30			
63	C	DH30	P30	UHS30	G55	UHS53	P20
	B	DH35	P35	UHS35			
80	C	DH35	P35	UHS35	G75	UHS70	P24
	B	DH40	P40	UHS40			
100	C	DH40	P40	UHS40	G95	UHS85	G30
	B	DH56	P56	UHS56			G40
125	C	DH56	P56	UHS56	G120	UHS112	G40
	B	DH70	P70	UHS70			G45
150	C	DH65	P65	UHS65	G145	UHS136	G50
	B	DH85	P85	UHS85			G60

MDH Tie-rod mold cylinders
MDC Compact mold cylinders

Features & spec. of limit switch

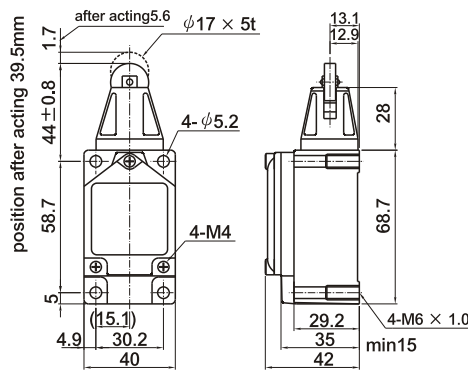
spec.	WLD2-Q		external dimension				
							
operating speed	1mm~1m/sec.		position after acting 39.5mm 1.7 44±0.8 58.7 5 4.9 30.2 40 after acting 5.6 φ17 × 5t 4-φ5.2 4-M4 (15.1) 29.2 35 42 13.1 12.9 28 68.7 4-M6 × 1.0 min15 ※ stainless roller				
operating frequency	mechanical	120 times/min					
	electrical feature	30 times/min					
fix frequency	50/60Hz						
insulated resistance	100MΩ above(DC500V)						
contact	25mΩ below(initiate)						
resistance insulated voltage	250v(EN60947-5-1)						
temperature	-10~+80°C			life	electrical feature	above 1500 million times	
moisture	95%RH above				mechanical feature	above 75 million times (AC125V,10A insulated load)	
protection	IP67						

GENTLE AUTOMATIC SOLUTION SDN BHD

No.36, Jalan Industri USJ 1/13, Taman Perindustrian USJ 1, 47600 Subang Jaya, Selangor.

TEL: 603-8023 7743 / 8743 FAX: 603-8023 9743

email:sales@gentle.com.my

Order form

MDH A — 70 — FA — C — 100 × 200 — A1 — B1 — C1 — 1 — L2
 ① ② ③ ④ ⑤ ⑥ ⑦ ⑧ ⑨ ⑩ ⑪

MDH Tie-rod mold cylinders
MDC Compact mold cylinders

MDH : Tie-rod mold cylinders		
①	kinds	(1) A : double acting (2) C : dual rods
②	max. working oressure (kgf/cm ²)	(1)70 (70Mpa) (2)140 (140Mpa)
③	mounting	Only "FA" type provided
④	rod(mm)	C : C class B : B class note : 1.standard MDH-70 withC class rods 2.standard MDH-140 with B class rods 3.please pecify if MDH-70 with B class rods or MDH-140 with C class rods is needed.
⑤	bore(mm)	40 , 50 , 63 , 80 , 100 , 125 , 150
⑥	stroke(mm)	based on customer request
⑦	rod end	(1)A1 : single neck type (2)A2 : dual necks type (3)A3 : external thread type
⑧	connecting plate	(1)B1 : thick round type (2)B2 : square type (3)B3 : thin round type
⑨	rod connector	(1)C1 : neck type (2)C2 : external thread type
⑩	seal	(1)1 : (PU)(standard use) (2)2 : (NBR) (3)3 : (FPM)
⑪	limit switch	(1)L : limit switch(WLD2-Q model is standard) (2)q'ty : 2 pieces note : if not specify here, standard WLD2-Q model will be used.

GENTLE AUTOMATIC SOLUTION SDN BHD

No.36, Jalan Industri USJ 1/13, Taman Perindustrian USJ 1, 47600 Subang Jaya, Selangor.

TEL: 603-8023 7743 / 8743 FAX: 603-8023 9743

email:sales@gentle.com.my

Internal dimension

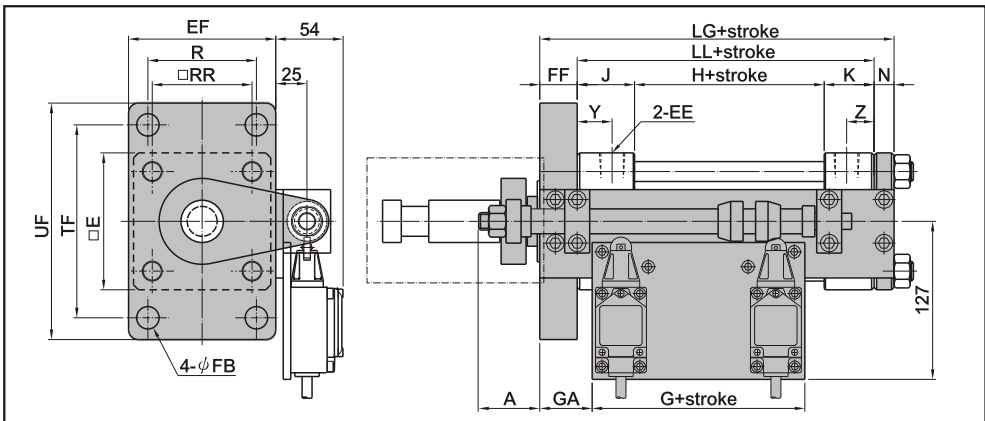

MDH Tie-rod mold cylinders
MDC Compact mold cylinders

Symbol bore	E	RR	FF	H	J	K	N	Y	Z	EE	EF	FB	TF	UF	R	LL	LG	GA	G
40	65	45	30	50	36	26	16	21	13	RC3/8	69	11	95	118	46	112	158	48	90.5
50	75	52	30	58	42	34	16	27	19	RC3/8	85	14	115	145	58	134	180	48	90.5
63	90	63	30	58	42	34	16	27	19	RC1/2	98	18	132	165	65	134	180	48	90.5
80	110	80	33	62	46	40	16	28	22	RC1/2	118	18	155	190	87	148	194	48	90.5
100	135	102	36	74	50	40	16	30	20	RC3/4	150	22	190	230	109	164	216	50	90.5
125	165	122	42	83	58	48	16	38	28	RC3/4	175	26	224	272	130	189	247	53	90.5
150	196	148	48	89	58	48	16	38	28	RC3/4	210	30	270	320	155	195	259	56	90.5

Flange

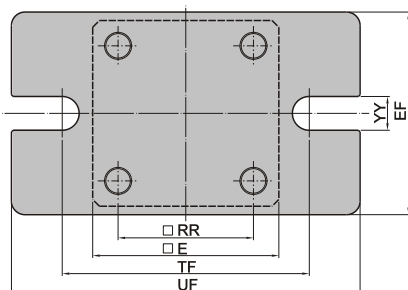

Symbol bore	E	RR	FF	EF	UF	TF	YY
40	65	45	30	69	120	85	14
50	75	52	30	85	150	102	18
63	90	63	30	98	185	125	22
80	110	80	33	118	205	145	22
100	135	102	36	150	250	175	26
125	165	122	42	175	290	210	30
150	196	148	48	210	335	245	33

note : EF 、 UF 、 TF 、 FF 、 YY dimensions can be attached based on the customer's need.

GENTLE AUTOMATIC SOLUTION SDN BHD

No.36, Jalan Industri USJ 1/13, Taman Perindustrian USJ 1, 47600 Subang Jaya, Selangor.

TEL: 603-8023 7743 / 8743 FAX: 603-8023 9743

email:sales@gentle.com.my

MDH rod end

MDH Tie-rod mold cylinders
MDC Compact mold cylinders

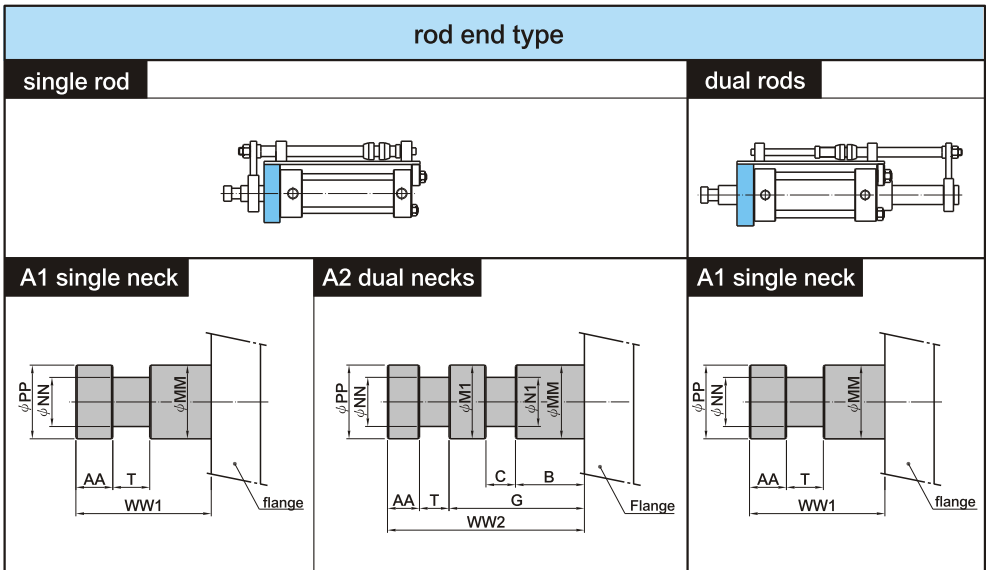

A3 external thread type

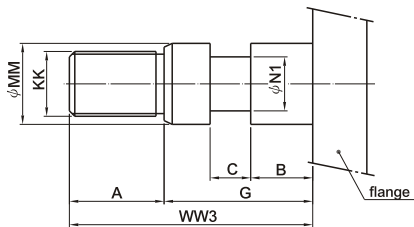

symbol bore	B	C	G
40	5	22	40
50	5	22	40
63	5	22	40
80	10	22	45
100	10	22	45
125	10	22	50
150	10	22	50

symbol bore	B class rod												C class rod											
	MM	A	AA	KK	M1	NN	N1	PP	T	WW1	WW2	WW3	MM	A	AA	KK	M1	NN	N1	PP	T	WW1	WW2	WW3
40	25	30	15	M20×1.5	25	18	20	25	15	50	70	70	20	25	15	M16×1.5	20	15	16	20	15	50	70	65
50	30	35	15	M24×1.5	30	22	25	30	15	50	70	75	25	30	15	M20×1.5	25	18	20	25	15	50	70	70
63	35	45	18	M30×1.5	35	25	30	34	22	60	80	85	30	35	15	M24×1.5	30	22	25	30	15	50	70	75
80	40	55	18	M36×1.5	40	28	35	39	22	60	85	100	35	45	18	M30×1.5	35	25	30	34	22	60	85	90
100	56	70	20	M48×1.5	56	38	50	49	27	65	92	115	40	60	18	M36×1.5	40	28	35	39	22	60	85	105
125	70	90	20	M64×2.0	70	49	65	63	27	65	97	140	56	75	20	M48×1.5	56	38	50	49	27	65	97	125
150	85	110	25	M76×2.0	85	58	80	70	30	70	110	160	65	85	20	M60×2.0	65	44	60	54	27	65	97	135

※dimensions can be altered based on the customer's need.

GENTLE AUTOMATIC SOLUTION SDN BHD

No.36, Jalan Industri USJ 1/13, Taman Perindustrian USJ 1, 47600 Subang Jaya, Selangor.

TEL: 603-8023 7743 / 8743 FAX: 603-8023 9743

email:sales@gentle.com.my

MDH connecting platet

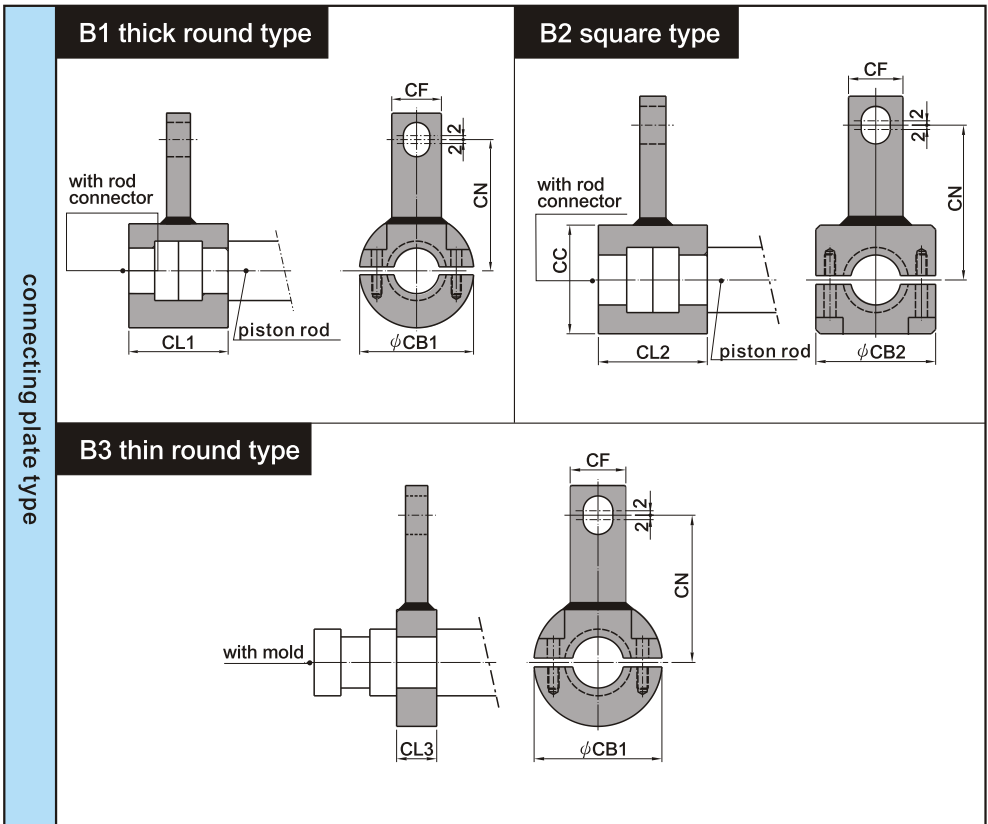

Symbol bore	B clasws rod									C class rod								
	MM	CB1	CB2	CC	CL1	CL2	CL3	CF	CN	MM	CB1	CB2	CC	CL1	CL2	CL3	CF	CN
40	25	69	58	40	60	60	20	32	59.5	20	69	53	40	60	60	20	32	59.5
50	30	69	63	45	60	60	20	32	67.5	25	69	58	40	60	60	20	32	67.5
63	35	69	68	50	80	80	20	32	74	30	69	63	45	60	60	20	32	74
80	40	69	73	58	80	80	20	32	84	35	69	68	50	80	80	20	32	84
100	56	89	88	74	87	87	20	38	100	40	69	73	58	80	80	20	32	100
125	70	99	98	88	87	87	20	38	113	56	89	88	74	87	87	20	38	113
150	85	119	118	108	105	105	20	38	130	65	99	98	88	87	87	20	38	130

※dimensions can be altered based on the customer's need.

GENTLE AUTOMATIC SOLUTION SDN BHD

No.36, Jalan Industri USJ 1/13, Taman Perindustrian USJ 1, 47600 Subang Jaya, Selangor.

TEL: 603-8023 7743 / 8743 FAX: 603-8023 9743

email:sales@gentle.com.my

MDH rod connector

MDH Tie-rod mold cylinders
MDC Compact mold cylinders

rod connector type

C1 neck

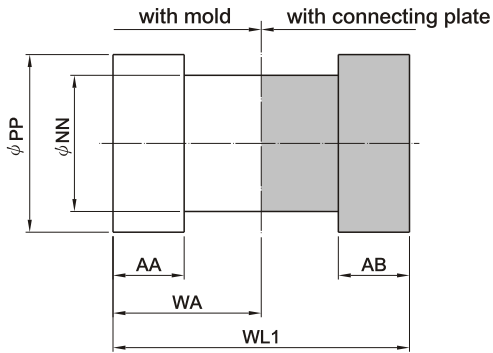

C2 external thread

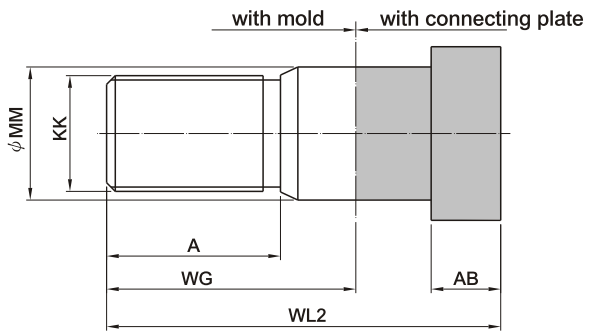

Symbol bore	B clasws rod											C class rod										
	MM	A	AA	AB	KK	NN	PP	WL1	WL2	WA	WG	MM	A	AA	AB	KK	NN	PP	WL1	WL2	WA	WG
40	25	30	15	15	M20×1.5	18	25	60	75	30	45	20	25	15	15	M16×1.5	15	20	60	70	30	40
50	30	35	15	15	M24×1.5	22	30	60	80	30	50	25	30	15	15	M20×1.5	18	25	60	75	30	45
63	35	45	18	18	M30×1.5	25	34	80	100	40	60	30	35	15	15	M24×1.5	22	30	60	80	30	50
80	40	55	18	18	M36×1.5	28	39	80	110	40	70	35	45	18	18	M30×1.5	25	34	80	100	40	60
100	56	70	20	20	M48×1.5	38	49	87	125	47	85	40	60	18	18	M36×1.5	28	39	80	115	40	75
125	70	90	20	20	M64×2.0	49	63	87	145	47	105	56	75	20	20	M48×1.5	38	49	87	130	47	90
150	85	110	25	25	M76×2.0	58	70	105	175	55	125	65	85	20	20	M60×2.0	44	54	87	140	47	100

※dimensions can be altered based on the customer's need.

GENTLE AUTOMATIC SOLUTION SDN BHD

No.36, Jalan Industri USJ 1/13, Taman Perindustrian USJ 1, 47600 Subang Jaya, Selangor.

TEL: 603-8023 7743 / 8743 FAX: 603-8023 9743

email:sales@gentle.com.my