

KP60 SERIES

Features

- Digital pressure gauge with battery power
- Programmable pressure unit : kPa、MPa、kgf/cm²、bar、psi、mmHg
- Power save function
- Battery meter displayed on LCD
- Backlight type available
- IP65 enclosure

PATENTED



SPECIFICATIONS

TYPE	(Vacuum)		(Positive)	
	KP60V	KP60VL	KP60P	KP60PL
Rated pressure range	0 ~ -101 kPa		0.000 ~ 1.000 MPa	
Display pressure range	10 ~ -101 kPa		-0.100 ~ 1.000 MPa	
Withstand pressure	300 kPa		1.5 MPa	
Applicable fluid	Filtered air, incombustible and non-corrosive gases			
Pressure resolution	kPa	1	-	
	MPa	-	0.001	
	kgf/cm ²	-	0.01	
	bar	0.01	0.01	
	psi	0.1	0.1	
mmHg	1	-		
Battery	CR 2032 lithium			
Back light	No	Yes	No	Yes
Battery life	3 years (5 times/day)	1 year (5 times/day)	3 years (5 times/day)	1 year (5 times/day)
Low-power indicator	Yes			
Battery replaceable	Yes			
Turn-on interval	Display turn off after 60 sec.			
Sampling rate	2 Hz (2 times/sec.)			
Programmable pressure unit	psi, bar, mmHg and kPa user selectable		psi, bar, kgf/cm ² and MPa user selectable	
Repeatability	±1% F.S. ±1digit		±0.2% F.S. ±1digit	
LCD display	3 ½ digit, 7 segment			
Indicator accuracy	±2% F.S. ±1 digit (ambient temperature: 25 ±3 °C)			
Environment	Enclosure	IP 65*1		
	Ambient temp. range	Operation: 0 ~ 50 °C, storage: -10 ~ 60 °C (No condensation or freezing)		
	Ambient humidity range	Operation/Storage: 35 ~ 85% RH (No condensation)		
	Vibration	Total amplitude 1.5mm or 10G, 10Hz-55Hz-10Hz scan for 1 minute, two hours each direction of X, Y and Z		
Shock	100m/s ² (10G), 3 times each in direction of X, Y and Z			
Temperature characteristic	±2% F.S. of detected pressure (25 °C) at temp. range of 0-50 °C			
Port size	F1:R1/8", M5; F2:NPT1/8"NPT, #10-32 UNF; F3:G1/8"(BSPP), M5; F4:R1/4", M5; F5:NPT1/4", #10-32 UNF; F6:G1/4"(BSPP), M5			
Weight	Approx. 40g			

*1. Air tube must be installed to maintain IP65.

PANEL DESCRIPTION



GENTLE AUTOMATIC SOLUTION SDN BHD

No. 36 Jalan Industri USJ 1/13, Taman Perindustrian USJ 1, 47600 Subang Jaya, Selangor.

TEL: 603-8023 7743 / 8743 FAX: 603-8023 9743 email: sales@gentle.com.my

ORDERING INFORMATION

K P 6 0 P □ - F 1

Pressure Range

V : Vacuum (10 ~ -101 kPa)
 P : Positive (-0.100 ~ 1.000 MPa)

Back Light

Blank : Back light unavailable
 L : Back light available

Optional Parts

BT-5 : Mounting bracket
 BT-6 : Mounting bracket
 PA-C : Panel adapter
 PA-D : Panel adapter + Front protective lid

Pressure Port

F1 : R1/8", M5
 F2 : NPT1/8", #10-32 UNF
 F3 : G1/8"(BSPP), M5
 F4 : R1/4", M5
 F5 : NPT1/4", #10-32 UNF
 F6 : G1/4"(BSPP), M5

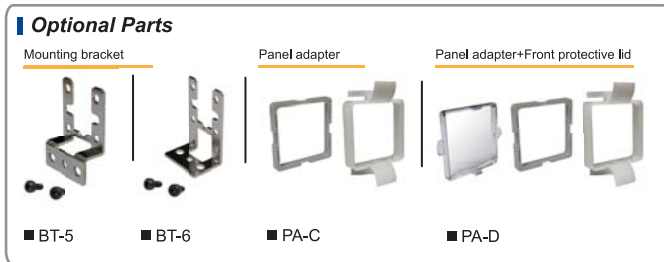

DIMENSIONS

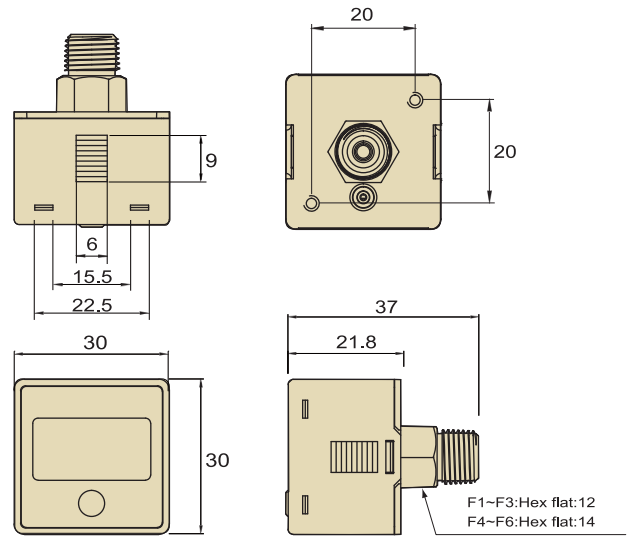

OPTIONAL PARTS DIMENSIONS

1 Mounting Bracket

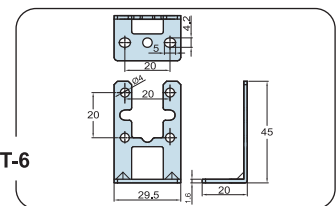
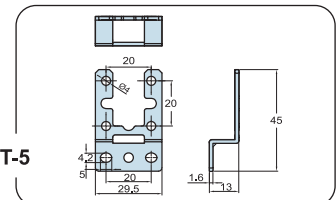
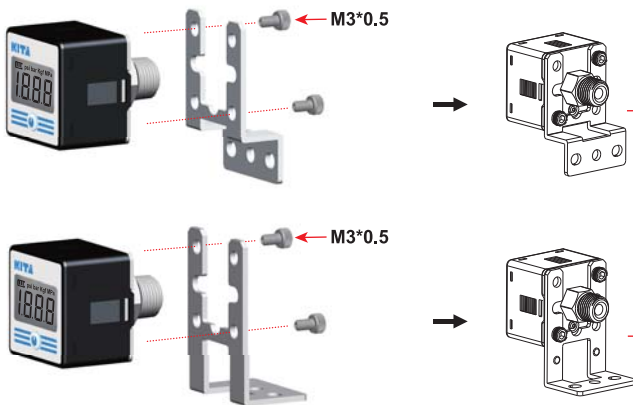

2 Panel Mount Adapter + Front Protective Lid

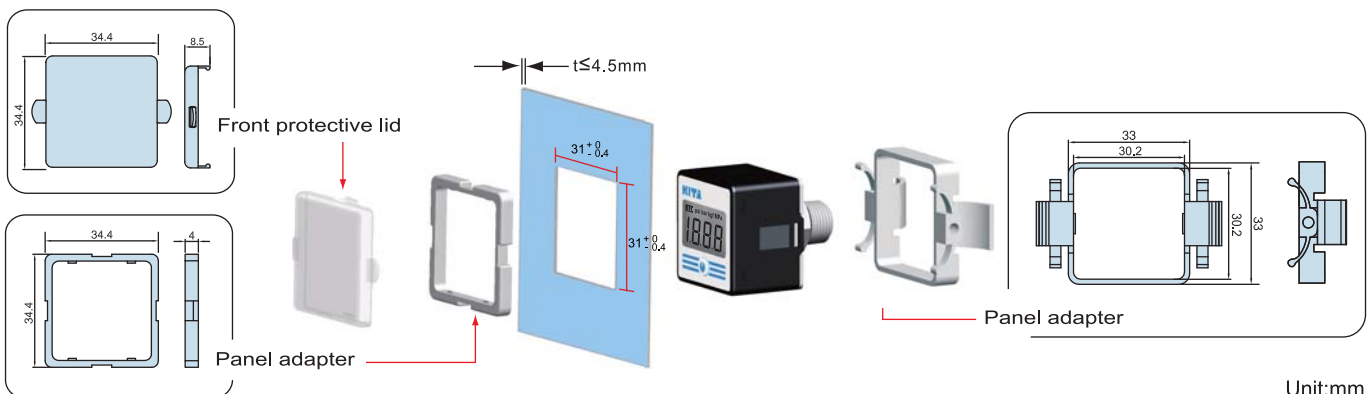

Unit:mm