

Compact Cylinder ISO Standard (21287)

C55 Series

ø20, ø25, ø32, ø40, ø50, ø63, ø80, ø100

RoHS

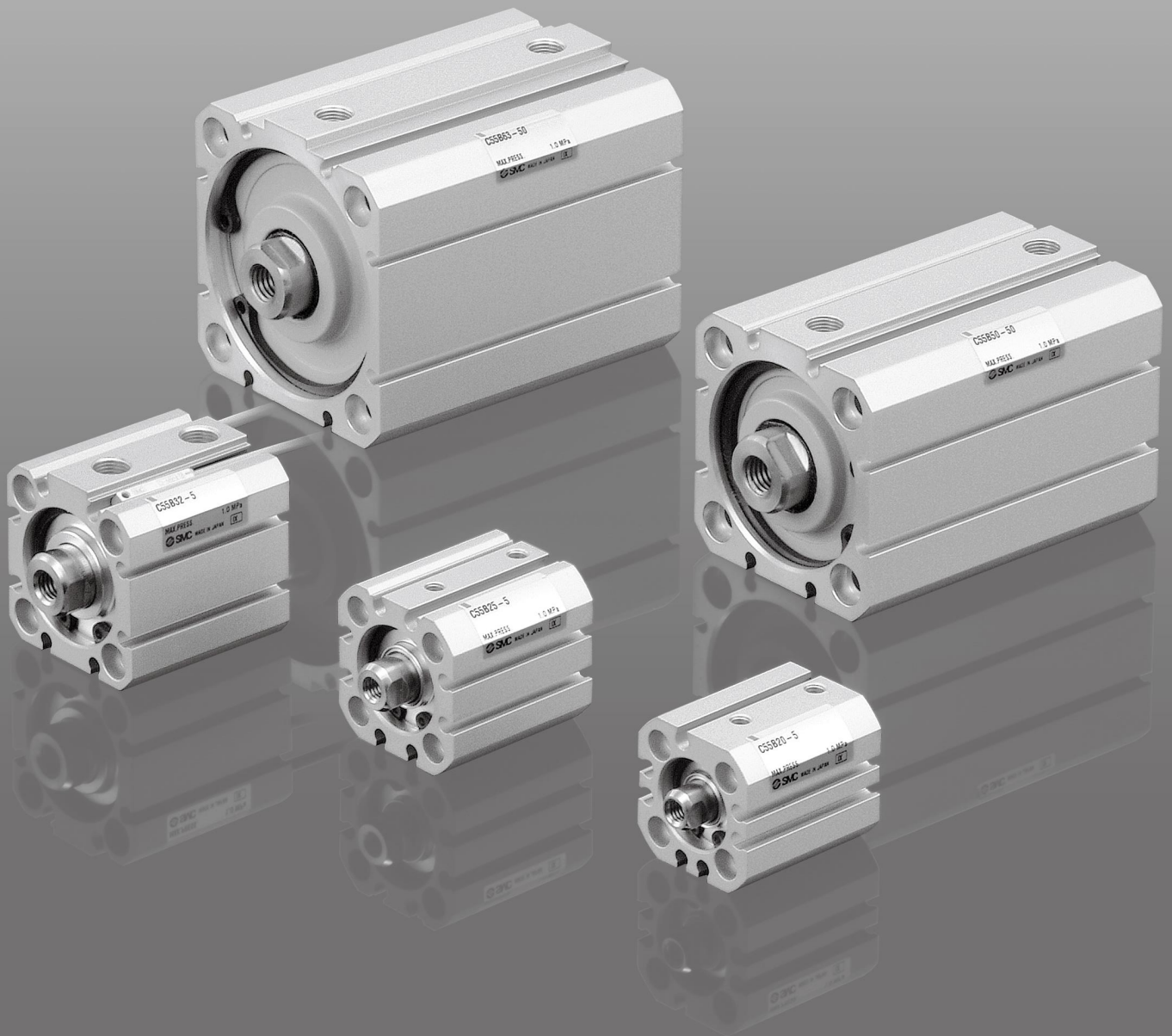

- C85
- C85W
- C85-ST
- C85K
- C85K-ST
- C85R
- C75
- C75W
- C75-ST
- C75K
- C75K-ST
- C75R
- CP96
- CP96K
- C96
- C96K
- C96Y
- C55
- Auto Switch
- Made to Order
- Related Products

ISO Standards

Compact Cylinder Double Acting, Single Rod

C55 Series

ø20, ø25, ø32, ø40, ø50, ø63, ø80, ø100



How to Order

C55 B 20 - 10 - [] - []

With auto switch **CD55 B 20 - 10** - [] - **M9B S** - []

• **With auto switch (Built-in magnet)**

• **Mounting**

B	Through-hole/Both ends tapped common (Standard)
L	Foot
F	Rod flange
G	Head flange
C	Single clevis

• **Bore size**

20	20 mm
25	25 mm
32	32 mm
40	40 mm
50	50 mm
63	63 mm
80	80 mm
100	100 mm

• **Auto switch**

Nil	Without auto switch (Built-in magnet cylinder)
-----	--

* For applicable auto switches, refer to the table below.
* Auto switches are shipped together, but not assembled.

• **Number of auto switches**

Nil	2
S	1
n	n

• **Auto switch**

Nil	Without auto switch (Built-in magnet cylinder)
-----	--

* For applicable auto switches, refer to the table below.
* Auto switches are shipped together, but not assembled.

• **Rod end thread**

Nil	Female rod end
M	Male rod end

* A rubber bumper comes as standard.

• **Cylinder stroke [mm]**
Refer to page 204 for standard and intermediate strokes.

• **Made to Order**
For details, refer to the next page.

Applicable Auto Switches/Refer to the Web Catalog or Best Pneumatics for further information on auto switches.

Type	Special function	Electrical entry	Indicator light	Wiring (Output)	Load voltage		Auto switch model		Lead wire length [m]					Pre-wired connector	Applicable load		
					DC	AC	Perpendicular	In-line	0.5 (Nil)	1 (M)	3 (L)	5 (Z)	None (N)				
Solid state auto switch	—	Grommet	Yes	3-wire (NPN)	24 V	—	M9NV	M9N	√	√	√	√	—	√	IC circuit	Relay, PLC	
				3-wire (PNP)					√	√	√	√	—	√			
				2-wire					√	√	√	√	—	√			
				3-wire (NPN)					√	√	√	√	—	√			
	3-wire (PNP)			√	√	√			√	—	√	IC circuit					
	2-wire			√	√	√			√	—	√						
	3-wire (NPN)			√	√	√			√	—	√						
	3-wire (PNP)			√	√	√			√	—	√						
Water-resistant (2-color indicator)	—	M9NAV*1	M9NA*1	√	√	√	√	—	√	IC circuit							
3-wire (PNP)				√	√	√	√	—	√								
2-wire				√	√	√	√	—	√								
2-wire (Non-polar)				—	—	—	—	—	—								
Magnetic field resistant (2-color indicator)	—	—	—	—	—	—	—	—	—	—	—	—					
Reed auto switch	—	Grommet	Yes	3-wire (NPN equivalent)	24 V	—	A96V	A96	√	—	√	—	—	—	√	IC circuit	—
				2-wire					√	√	√	√	—	—	—		
			No	2-wire	24 V	5 V, 12 V	100 V	A93V*2	A93	√	√	√	√	—	—	—	Relay, PLC
						5 V, 12 V	100 V or less	A90V	A90	√	—	√	—	—	—	—	IC circuit

*1 Water-resistant type auto switches can be mounted on the above models, but SMC cannot guarantee water resistance.

*2 1 m lead wire is only applicable to the D-A93.

Lead wire length symbols: 0.5 m..... Nil (Example) M9NW
 1 m..... M (Example) M9NWM
 3 m..... L (Example) M9NWL
 5 m..... Z (Example) M9NWX

* Solid state auto switches marked with "√" are produced upon receipt of order.

* Since there are other applicable auto switches than listed above, refer to the Web Catalog or Best Pneumatics for details.

* Auto switches are shipped together, but not assembled.

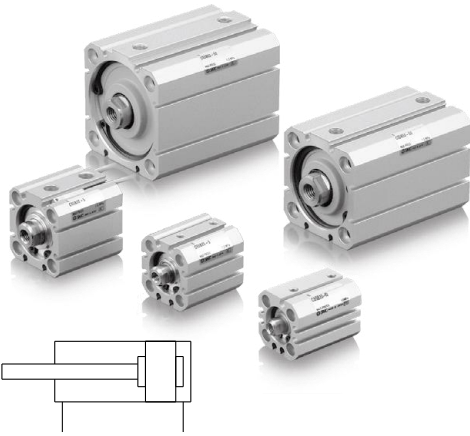

⚠ Caution

Be sure to read this before handling the products.

1. Refer to page 219 for safety instructions and "Handling Precautions for SMC Products" (M-E03-3) for actuator and auto switch precautions.
2. This product should not be used as a stopper.
3. Use the G thread fittings for this cylinder.



Made to Order
 (For details, refer to pages 216 and 217.)

Symbol	Specifications
-XAm	Change of rod end shape
-XC6	Made of stainless steel (Rod, retaining ring and rod end nut made of stainless steel)

Mounting Bracket Part No.

Bore size [mm]	Foot	Flange	Single clevis
20	C55-L020	C55-F020	C55-C020
25	C55-L025	C55-F025	C55-C025
32	C55-L032	C55-F032	C55-C032
40	C55-L040	C55-F040	C55-C040
50	C55-L050	C55-F050	C55-C050
63	C55-L063	C55-F063	C55-C063
80	C55-L080	C55-F080	C55-C080
100	C55-L100	C55-F100	C55-C100

- Order two foot brackets per cylinder.
- Parts belonging to each bracket are as follows.
 Foot, Flange, Single clevis/Body mounting bolt

Theoretical Output



Bore size [mm]	Operating direction	Operating pressure [MPa]		
		0.3	0.5	0.7
20	IN	71	118	165
	OUT	94	157	220
25	IN	113	189	264
	OUT	147	245	344
32	IN	181	302	422
	OUT	241	402	563
40	IN	317	528	739
	OUT	377	628	880
50	IN	495	825	1150
	OUT	589	982	1370
63	IN	841	1400	1960
	OUT	935	1560	2180
80	IN	1360	2270	3180
	OUT	1510	2520	3520
100	IN	2150	3580	5010
	OUT	2360	3930	5500

Specifications

Type	Pneumatic (Non-lube)	
Action	Double acting, Single rod	
Fluid	Air	
Proof pressure	1.5 MPa	
Maximum operating pressure	1.0 MPa	
Minimum operating pressure	0.05 MPa (ø20 to ø63), 0.03 MPa (ø80, ø100)	
Ambient and fluid temperature	Without auto switch: -10 to 70°C (No freezing) With auto switch: -10 to 60°C (No freezing)	
Cushion	Rubber bumper on both ends	
Stroke length tolerance*1	+1.0 0 mm	
Piston speed	ø20 to ø63	50 to 500 mm/s
	ø80, ø100	50 to 300 mm/s

*1 Stroke length tolerance does not include the amount of bumper change.

Standard Strokes

Bore size [mm]	Standard stroke [mm]
20 to 63	5, 10, 15, 20, 25, 30, 35, 40, 45, 50, 60, 80, 100, 125, 150
80, 100	10, 15, 20, 25, 30, 35, 40, 45, 50, 60, 80, 100, 125

Manufacture of Intermediate Stroke

Description	Dealing with the stroke in 1 mm increments by using an exclusive body with the specified stroke
Part no.	Refer to "How to Order" for the standard model no. (page 203)
Stroke range	6 to 149
Example	Part no.: C55B32-47
	Makes 47 stroke tube

Weights

Without Auto Switch

Bore size [mm]	Cylinder stroke [mm]															Unit: g
	5	10	15	20	25	30	35	40	45	50	60	80	100	125	150	
20	111	124	137	150	163	176	189	202	215	228	254	306	357	422	487	
25	152	168	183	199	214	230	246	261	277	292	323	386	448	526	603	
32	250	273	295	317	339	362	384	406	428	451	495	584	673	785	896	
40	315	339	364	388	412	436	461	485	509	533	582	679	776	897	1018	
50	497	534	570	607	644	681	718	755	791	828	902	1049	1197	1381	1565	
63	677	717	757	797	837	877	917	957	997	1037	1117	1277	1437	1638	1838	
80	—	1164	1223	1281	1339	1398	1456	1514	1573	1631	1748	1981	2214	2506	—	
100	—	2213	2295	2377	2459	2541	2623	2705	2787	2870	3034	3362	3690	4101	—	

With Auto Switch (Built-in magnet)

Bore size [mm]	Cylinder stroke [mm]															Unit: g
	5	10	15	20	25	30	35	40	45	50	60	80	100	125	150	
20	113	126	139	152	165	178	191	204	216	229	255	307	359	424	489	
25	154	170	185	201	217	232	248	263	279	294	325	388	450	528	606	
32	254	277	299	321	343	366	388	410	432	455	499	588	677	788	900	
40	319	344	368	392	416	441	465	489	513	537	586	683	780	901	1022	
50	502	539	575	612	649	686	723	760	796	833	907	1054	1202	1386	1570	
63	685	725	765	805	845	885	925	965	1005	1045	1125	1285	1445	1645	1845	
80	—	1188	1246	1305	1363	1421	1480	1538	1596	1654	1771	2004	2238	2529	—	
100	—	2248	2330	2412	2494	2577	2659	2741	2823	2905	3069	3397	3726	4136	—	

Add each weight of auto switches and mounting brackets when auto switches are mounted. Refer to Best Pneumatics for auto switch weight.



C55 Series

Allowable Lateral Load

Make sure to operate strictly within the allowable lateral load range to the rod end.

Operation outside of this range may result in shorter service life or damage to the device.

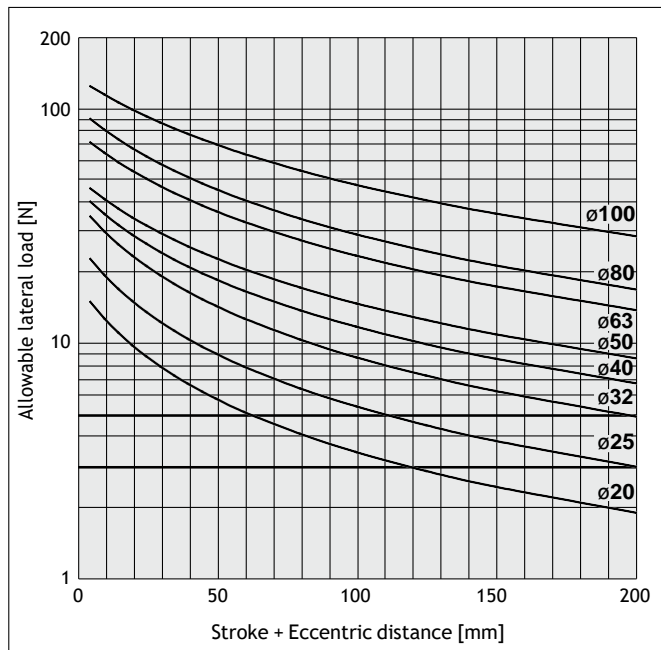
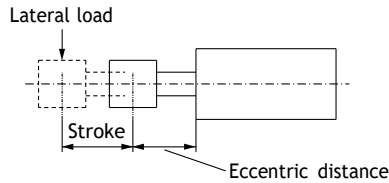

Allowable Kinetic Energy

Make sure to operate strictly within the allowable range of the load mass and maximum speed.

Operation outside of this range may cause excessive impact, which may result in the damage to the device.

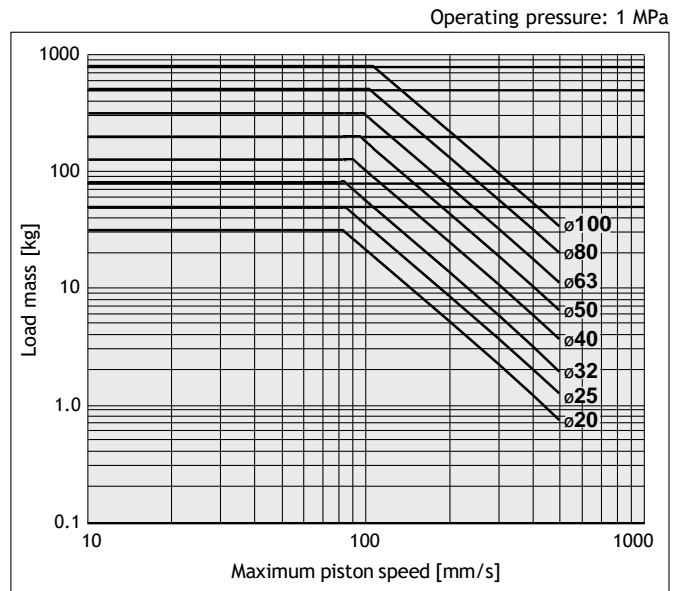

* For details about model selection, refer to "Model Selection" in Best Pneumatics.

Mounting Bolt

Through hole type mounting bolts are available.
 Refer to the following for ordering procedures.
 Order the actual number of bolts that will be used.

Example) CQ-M4x45L 4 pcs.

Material: Chromium molybdenum steel
Surface treatment: Zinc chromated

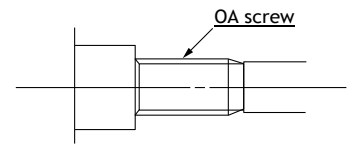
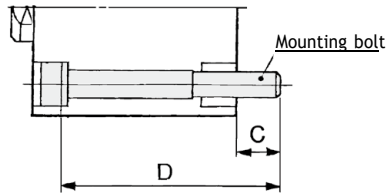

* When using the through-hole mounting bolts for bore sizes 20 to 63 mm, be sure to use the attached flat washers.

Mounting Bolt for C55

Model	C	D	Mounting bolt part no.
Cm55B20-5	7.2	45	CQ-M4 x 45L
-10		50	x 50L
-15		55	x 55L
-20		60	x 60L
-25		65	x 65L
-30		70	x 70L
-35		75	x 75L
-40		80	x 80L
-45		85	x 85L
-50		90	x 90L
-60	Use the OA screw provided on the cylinder tube to secure the cylinder.		
-80			
-100			
-125			
-150			
Cm55B25-5	10.2	50	CQ-M4 x 50L
-10		55	x 55L
-15		60	x 60L
-20		65	x 65L
-25		70	x 70L
-30		75	x 75L
-35		80	x 80L
-40		85	x 85L
-45		90	x 90L
-50		95	x 95L
-60	Use the OA screw provided on the cylinder tube to secure the cylinder.		
-80			
-100			
-125			
-150			
Cm55B32-5	10	55	CQ-M5 x 55L
-10		60	x 60L
-15		65	x 65L
-20		70	x 70L
-25		75	x 75L
-30		80	x 80L
-35		85	x 85L
-40		90	x 90L
-45		95	x 95L
-50		100	x 100L
-60	110	x 110L	
-80	130	x 130L	
-100	150	x 150L	
-125	Use the OA screw provided on the cylinder tube to secure the cylinder.		
-150			

Model	C	D	Mounting bolt part no.
Cm55B40-5	9	55	CQ-M5 x 55L
-10		60	x 60L
-15		65	x 65L
-20		70	x 70L
-25		75	x 75L
-30		80	x 80L
-35		85	x 85L
-40		90	x 90L
-45		95	x 95L
-50		100	x 100L
-60	110	x 110L	
-80	130	x 130L	
-100	150	x 150L	
-125	Use the OA screw provided on the cylinder tube to secure the cylinder.		
-150			
Cm55B50-5	8.4	55	CQ-M6 x 55L
-10		60	x 60L
-15		65	x 65L
-20		70	x 70L
-25		75	x 75L
-30		80	x 80L
-35		85	x 85L
-40		90	x 90L
-45		95	x 95L
-50		100	x 100L
-60	110	x 110L	
-80	130	x 130L	
-100	150	x 150L	
-125	Use the OA screw provided on the cylinder tube to secure the cylinder.		
-150			
Cm55B63-5	9.4	60	CQ-M6 x 60L
-10		65	x 65L
-15		70	x 70L
-20		75	x 75L
-25		80	x 80L
-30		85	x 85L
-35		90	x 90L
-40		95	x 95L
-45		100	x 100L
-50		105	x 105L
-60	115	x 115L	
-80	135	x 135L	
-100	155	x 155L	
-125	Use the OA screw provided on the cylinder tube to secure the cylinder.		
-150			

Model	C	D	Mounting bolt part no.
Cm55B80-10	11	70	CQ-M8 x 70L
-15		75	x 75L
-20		80	x 80L
-25		85	x 85L
-30		90	x 90L
-35		95	x 95L
-40		100	x 100L
-45		105	x 105L
-50		110	x 110L
-60		120	x 120L
-80	140	x 140L	
-100	160	x 160L	
-125	Use the OA screw provided on the cylinder tube to secure the cylinder.		
Cm55B100-10	13	85	CQ-M8 x 85L
-15		90	x 90L
-20		95	x 95L
-25		100	x 100L
-30		105	x 105L
-35		110	x 110L
-40		115	x 115L
-45		120	x 120L
-50		125	x 125L
-60		135	x 135L
-80	155	x 155L	
-100	175	x 175L	
-125	Use the OA screw provided on the cylinder tube to secure the cylinder.		

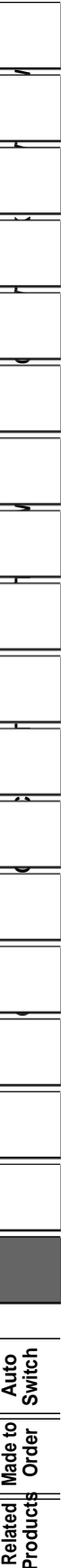

Auto Switch
 Made to Order
 Related Products

C55 Series

Construction

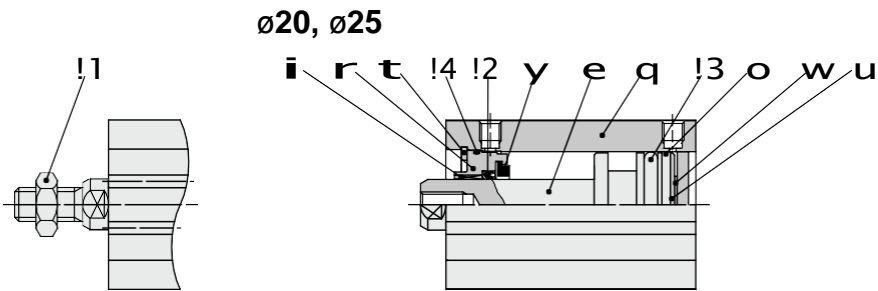

M: Male rod end

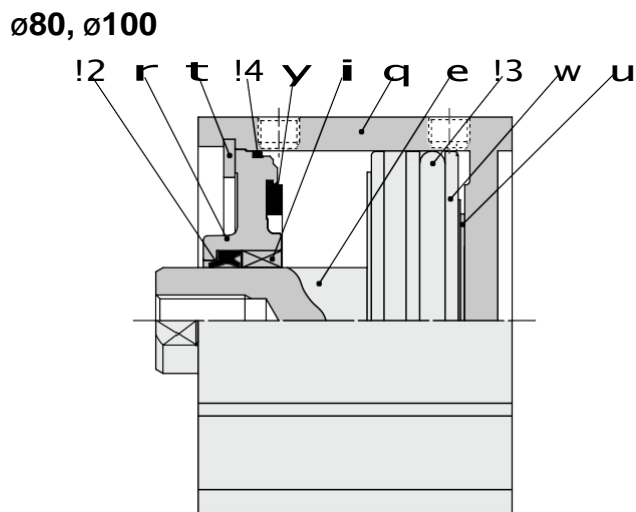
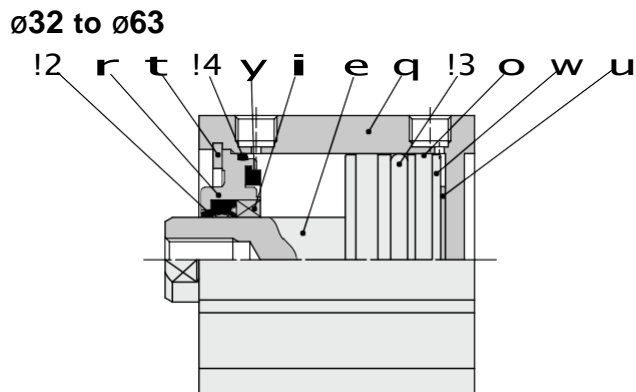

With auto switch (Built-in magnet)

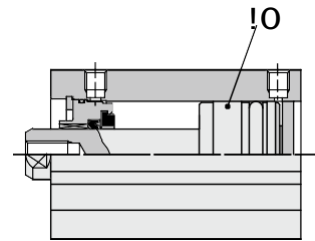

With auto switch (Built-in magnet)

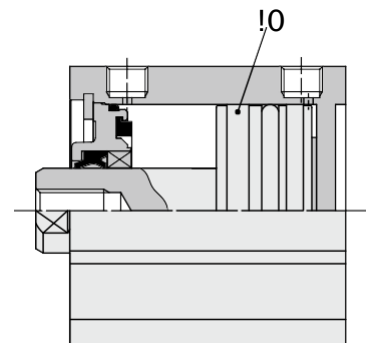

With auto switch (Built-in magnet)

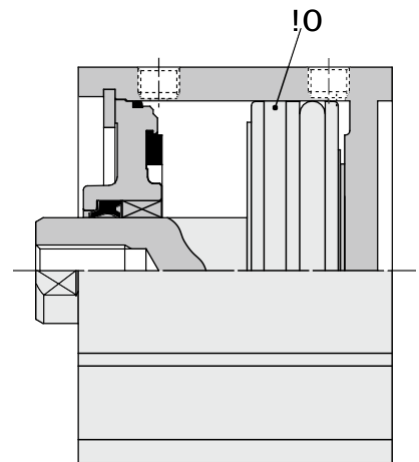

Component Parts

No.	Description	Material	Note
1	Cylinder tube	Aluminum alloy	Hard anodized
2	Piston	Aluminum alloy	Chromated
3	Piston rod	Stainless steel	ø20, ø25
		Carbon steel	ø32 to ø100 Hard chrome plating
4	Collar	Aluminum alloy	ø20 to ø40 Anodized
		Aluminum alloy casted	ø50 to ø100 Painted after chromated
5	Retaining ring	Carbon tool steel	Phosphate coated
6	Bumper A	Urethane	
7	Bumper B	Urethane	
8	Bushing	Bearing alloy	
9	Wear ring	Resin	ø20 to ø63
10	Magnet	—	
11	Rod end nut	Carbon steel	Trivalent zinc chromated
12	Rod seal	NBR	
13	Piston seal	NBR	
14	Tube gasket	NBR	

Replacement Parts/Seal Kit

Bore size [mm]	Kit no.	Contents
20	CQ2B20-PS	Kits include items !2, !3, !4 from the table.
25	CQ2B25-PS	
32	CQ2B32-PS	
40	CQ2B40-PS	
50	CQ2B50-PS	
63	CQ2B63-PS	
80	CQ2B80-PS	
100	CQ2B100-PS	

* Seal kits consist of items !2, !3 and !4, and can be ordered by using the seal kit number corresponding to each bore size.

Dimensions (With and without auto switch are the same size)

ø20, ø25

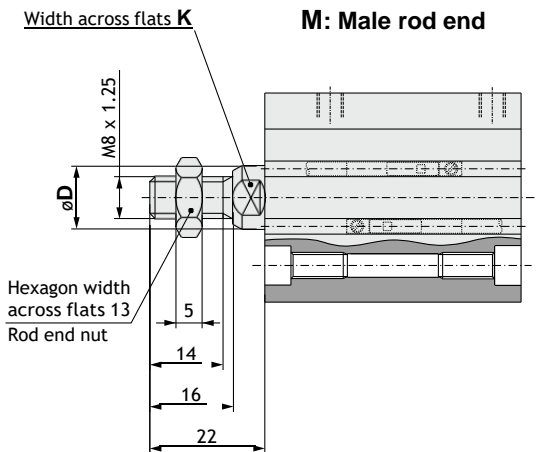
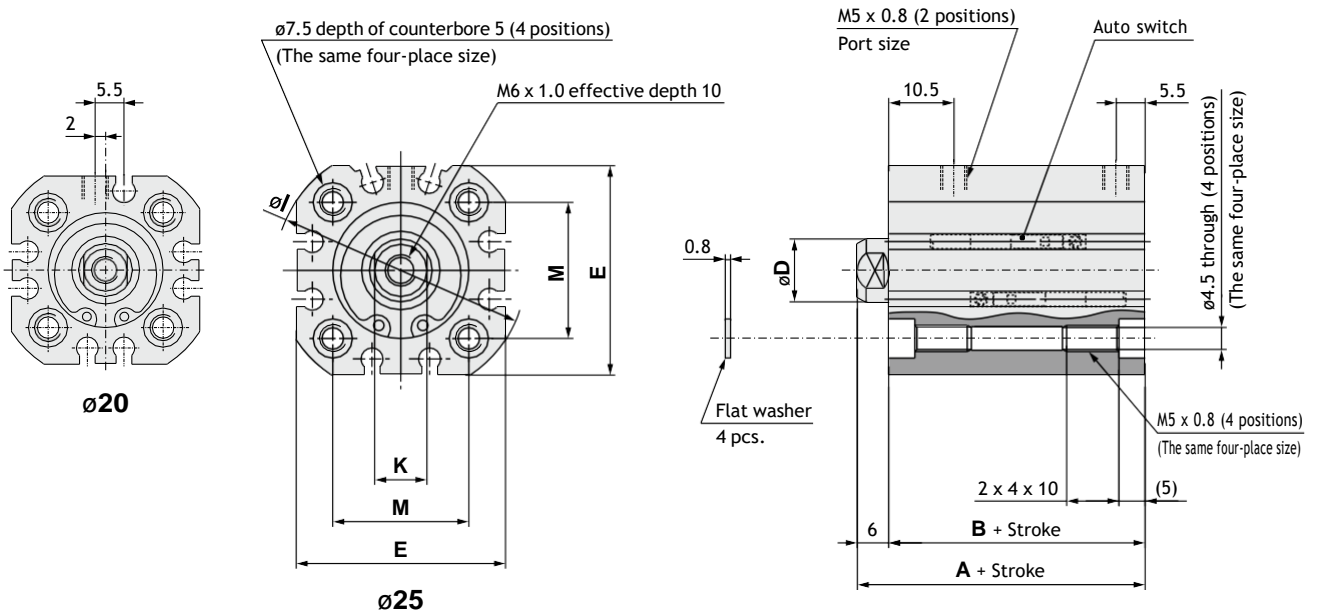

Standard Type [mm]

Bore size [mm]	A	B	D	E	I	K	M
20	43	37	10	36	43	8	22
25	45	39	12	40	48	10	26

Male Rod End [mm]

Bore size [mm]	D	K
20	10	8
25	12	10

- C85
- C85W
- C85-S/T
- C85K
- C85K-S/T
- C85R
- C75
- C75W
- C75-S/T
- C75K
- C75K-S/T
- C75R
- CP96
- CP96K
- C96
- C96K
- C96Y
- C55**
- Auto Switch
- Made to Order
- Related Products

C55 Series

Dimensions (With and without auto switch are the same size)

ø32 to ø63

øOB depth of counterbore 5
(4 positions)
(The same four-place size)

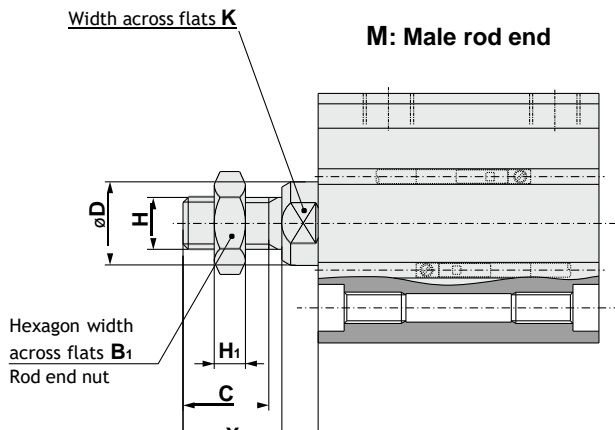
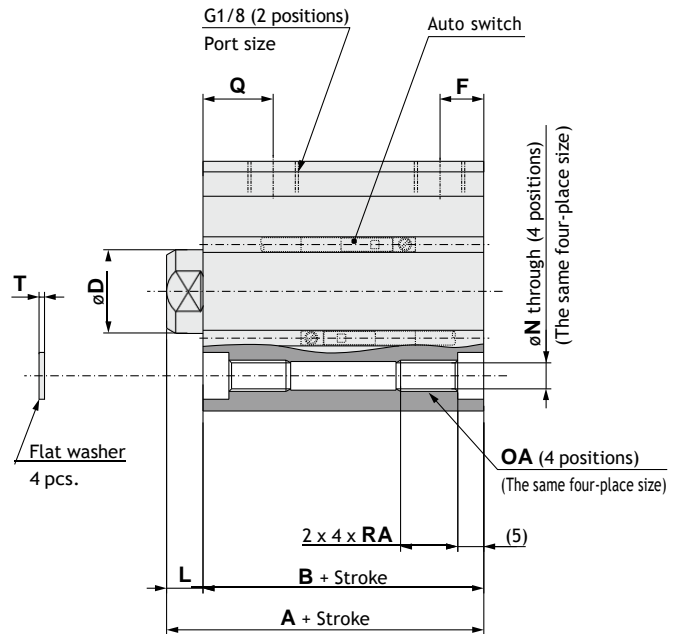
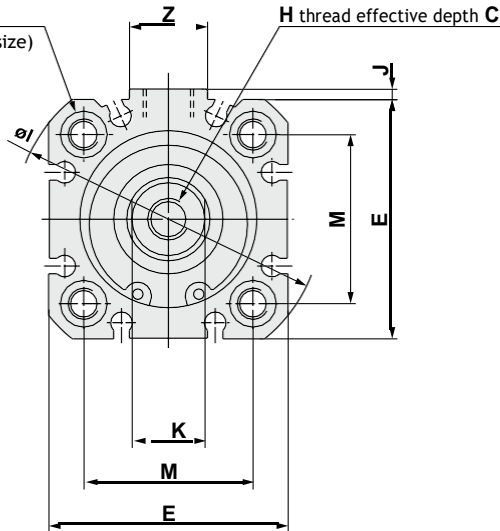

Bore size [mm]	B ₁	C	D	H	H ₁	K	L ₁	X
32	17	16.5	16	M10 x 1.25	6	14	26	19
40	17	16.5	16	M10 x 1.25	6	14	26	19
50	19	19.5	20	M12 x 1.25	7	17	30	22
63	19	19.5	20	M12 x 1.25	7	17	30	22

Male Rod End

[mm]

Standard Type

Bore size [mm]	A	B	C	D	E	F	H	I	J	K	L	M	N	OA	OB	Q	RA	T	Z
32	51	44	12	16	46	8.5	M8 x 1.25	59	2	14	7	32.5	5.5	M6 x 1.0	9	11	11	1	15
40	52	45	12	16	52	9.5	M8 x 1.25	67	3	14	7	38	5.5	M6 x 1.0	9	14.5	11	1	17
50	53	45	16	20	64	10.5	M10 x 1.5	82	2	17	8	46.5	6.6	M8 x 1.25	10.5	13.5	15	1.6	17
63	57	49	16	20	74	14.5	M10 x 1.5	96	3	17	8	56.5	6.6	M8 x 1.25	10.5	15.5	15	1.6	17

[mm]

Dimensions (With and without auto switch are the same size)

ø80, ø100

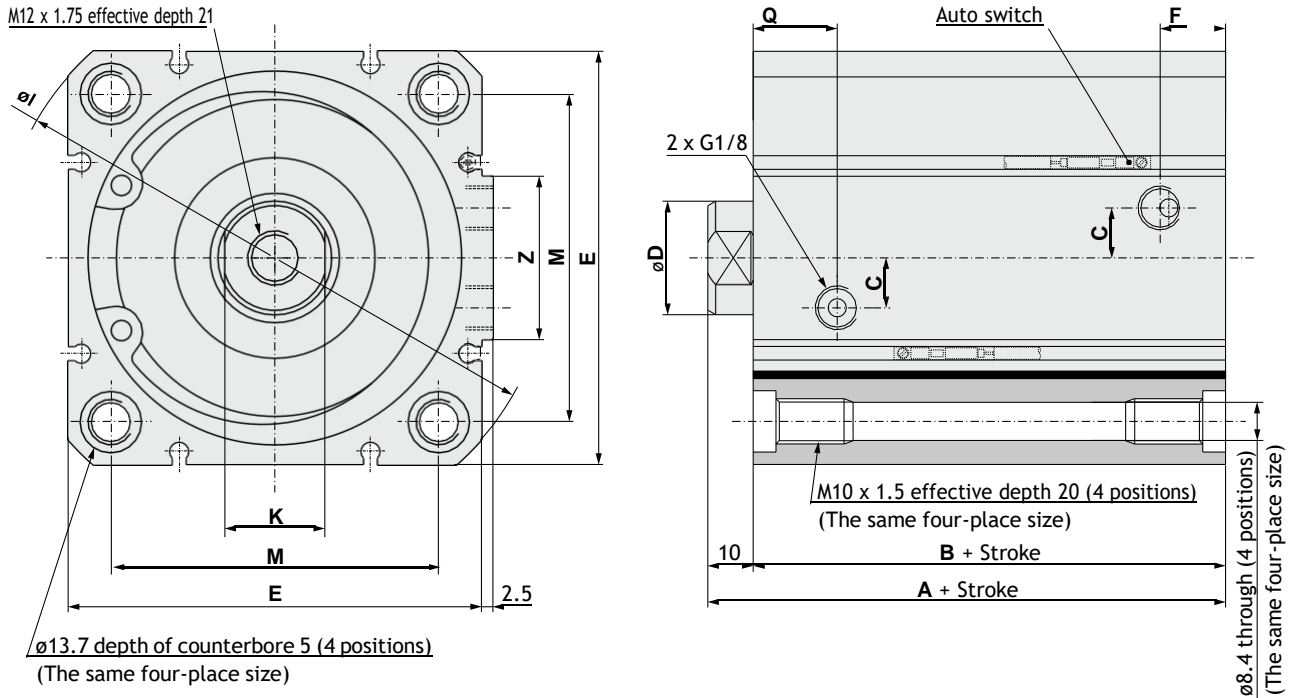

ø13.7 depth of counterbore 5 (4 positions)
 (The same four-place size)

M: Male rod end

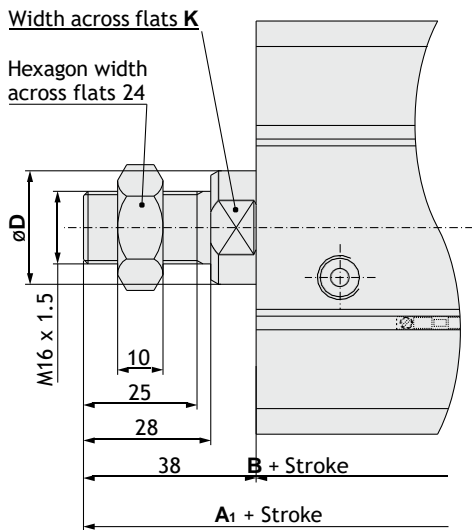

Standard Type

Bore size [mm]	A	B	C	D	E	F	I	K	M	Q	Z
80	64	54	11	25	91	15	121	22	72	19	36
100	77	67	14	30	111	18	145	27	89	26	42

Male Rod End [mm]

Bore size [mm]	A ₁
80	92
100	106.5

- C85
- C85W
- C85-S/T
- C85K
- C85K-S/T
- C85R
- C75
- C75W
- C75-S/T
- C75K
- C75K-S/T
- C75R
- CP96
- CP96K
- C96
- C96K
- C96Y
- C55**
- Auto Switch
- Made to Order
- Related Products

C55 Series

Moun GENTLE AUTOMATIC SOLUTION SDN BHD
 NO.36, Jalan Industri USJ 1/13, Taman Perindustrian USJ 1, 47600 Subang Jaya, Selangor, Malaysia
Foot b Tel: 603-8023 / 8743 Fax: 603-8023 9743 <http://www.gentle.com.my> email: sales@gentle.com.my

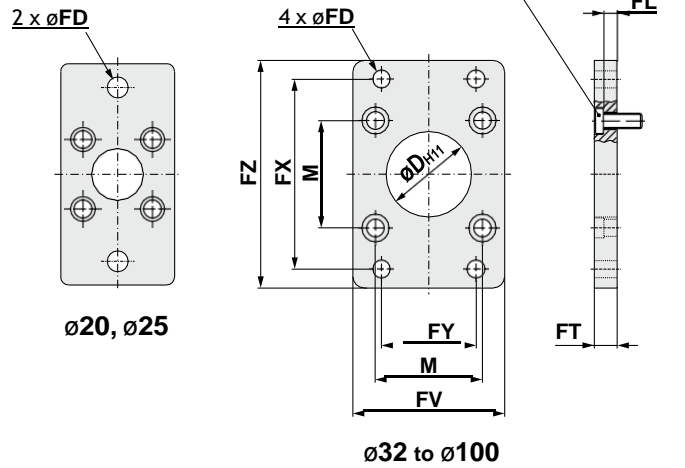
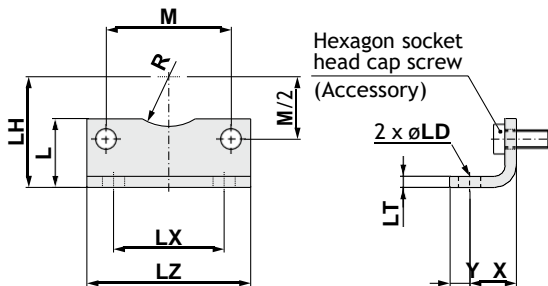

Bore size [mm]	L	LD	LH	LT	LX	LZ	M	R	X	Y	Hexagon socket head cap screw
20	22	7	27	4	22	36	22	8	16	7	M5
25	22	7	29	4	26	40	26	10	16	7	M5
32	24.5	7	33.5	4	32	46	32.5	15	16	7	M6
40	26	10	38	4	36	52	38	17.5	18	9	M6
50	31	10	45	5	45	64	46.5	20	21	9	M8
63	31	10	50	5	50	74	56.5	22.5	21	9	M8
80	38.5	12	63	6	63	96	72	—	26	11	M10
100	45	14.5	74	6	75	116	89	—	27	13	M10

Bore size [mm]	D	M	FD	FL	FT	FV	FX	FY	FZ	Hexagon socket head cap screw
20	16	22	6.6	2.8	8	38	55	—	68	M5
25	16	26	6.6	2.8	8	38	60	—	73	M5
32	30	32.5	7	5	10	50	64	32	79	M6
40	35	38	9	5	10	55	72	36	90	M6
50	40	46.5	9	6	12	70	90	45	110	M8
63	45	56.5	9	6	12	80	100	50	120	M8
80	45	72	12	8	16	100	126	63	153	M10
100	55	89	14	8	16	120	150	75	178	M10

Single clevis bracket

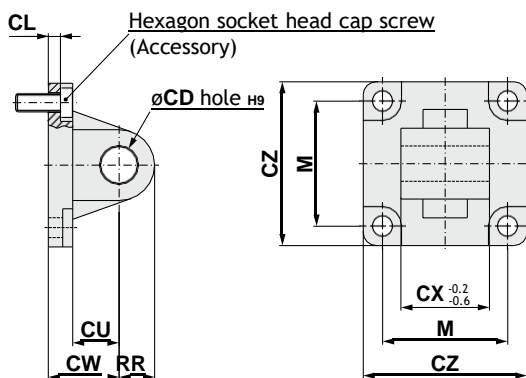

Bore size [mm]	CD _{H9}	CL	CU	CW	CX	CZ	M	RR	Hexagon socket head cap screw
20	8	3	12	20	16	35	22	9	M5
25	8	3	12	20	16	40	26	9	M5
32	10	5.5	12	22	26	45	32.5	9.5	M6
40	12	5.5	15	25	28	51	38	12	M6
50	12	6.5	15	27	32	64	46.5	12	M8
63	16	6.5	20	32	40	74	56.5	16	M8
80	16	10	20	36	50	94	72	16	M10
100	20	10	25	41	60	113	89	20	M10

C55 Series

Auto Switch Mounting

Auto Switch Proper Mounting Position (Detection at stroke end) and Mounting Height

Solid state auto switch
D-M9m
D-M9mW
D-M9mA
D-P3DW

Reed auto switch
D-A9m

ø20, ø25

ø32, ø40, ø50, ø63, ø80, ø100

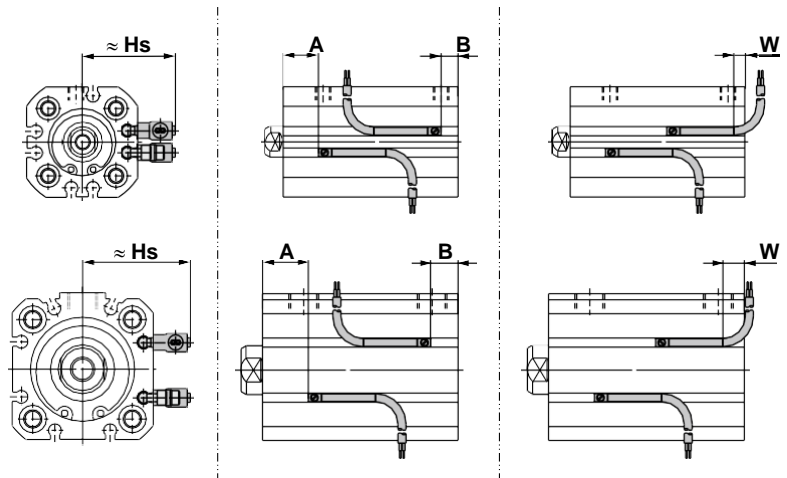

* Figures in the table below are used as a reference when mounting the auto switches for stroke end detection. Adjust the auto switch after confirming the operating condition in the actual setting.

Auto switch model	D-M9m D-M9mW			D-M9mA			D-A9m			D-P3DW			
	A	B	W	A	B	W	A	B	W	A	B	W	Hs
20	15.5	9.5	-0.5	15.5	9.5	-2.5	11.5	5.5	1 (3.5)	6.0	0.5	-3.0	30
25	16.5	11.5	1.5	16.5	11.5	-0.5	12.5	7.5	3 (5.5)	7	2.5	-1	32
32	18.5	13.5	3.5	18.5	13.5	1.5	14.5	9.5	5 (7.5)	9.5	4	1	35
40	17	16	6	17	16	4	13	12	7.5 (10)	8	7	3.5	38
50	13.5	19.5	9.5	13.5	19.5	7.5	9.5	15.5	11 (13.5)	4.5	10.5	7	44
63	14.5	22.5	12.5	14.5	22.5	10.5	10.5	18.5	14 (16.5)	5.5	13.5	10	49
80	20.5	21.5	11.5	20.5	21.5	9.5	16.5	17.5	13 (15.5)	11.5	12.5	9	57.5
100	28.5	26.5	16.5	28.5	26.5	14.5	24.5	22.5	18 (20.5)	19.5	17.5	14	67.5

The dimensions inside () is for D-A96.

Negative figures in the table W indicate an auto switch is mounted inward from the edge of the cylinder body.

Solid state auto switch
D-M9mV
D-M9mWV
D-M9mAV

Reed auto switch
D-A9mV

ø20, ø25

ø32, ø40, ø50, ø63, ø80, ø100

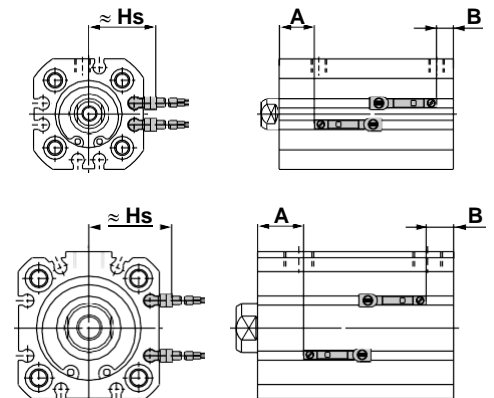

* Figures in the table below are used as a reference when mounting the auto switches for stroke end detection. Adjust the auto switch after confirming the operating condition in the actual setting.

Auto switch model	D-M9mV D-M9mWV D-M9mAV			D-A9mV		
	A	B	Hs	A	B	Hs
20	15.5	9.5	24	11.5	5.5	22
25	16.5	11.5	26	12.5	7.5	24
32	18.5	13.5	29	14.5	9.5	27
40	17	16	32	13	12	30
50	13.5	19.5	38	9.5	15.5	36
63	14.5	22.5	43	10.5	18.5	41
80	20.5	21.5	52	16.5	17.5	49.5
100	28.5	26.5	62	24.5	22.5	60

- C85
- C85W
- C85-S/T
- C85K
- C85K-S/T
- C85R
- C75
- C75W
- C75-S/T
- C75K
- C75K-S/T
- C75R
- CP96
- CP96K
- C96
- C96K
- C96Y
- C55
- Auto Switch
- Made to Order
- Related Products

C55 Series

The Number of Surfaces and Grooves Where an Auto Switch Can Be Mounted (As direct mounting)

The number of the surfaces and grooves where the auto switch can be mounted, by switch type, are shown in the table below.

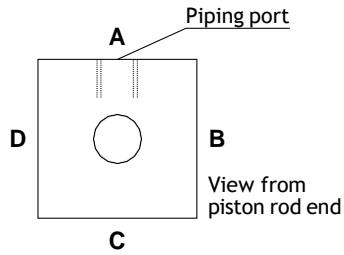

Mounting the D-P3DW on a $\phi 20$ to $\phi 25$ port surface interferes with the fitting, so it needs to be mounted on a place other than the port surface.

For $\phi 32$ to $\phi 100$, if the corner of the fitting hexagon interferes with the D-P3DW series, adjust the tightening of the fitting to eliminate the interference.

Also, in the case of interference with an elbow type fitting, direct the port of the fitting away from the D-P3DW series.

If you have any other questions, please contact SMC.

Auto switch model	D-M9m, A9m				D-P3DW				
	Bore size [mm]	A (Mounting groove no.)	B (Mounting groove no.)	C (Mounting groove no.)	D (Mounting groove no.)	A (Mounting groove no.)	B (Mounting groove no.)	C (Mounting groove no.)	D (Mounting groove no.)
20	✓ (1)	✓ (2)	✓ (2)	✓ (2)	u	✓ (2)	✓ (2)	✓ (2)	✓ (2)
25	✓ (2)	✓ (2)	✓ (2)	✓ (2)	u	✓ (2)	✓ (2)	✓ (2)	✓ (2)
32	✓ (2)	✓ (2)	✓ (2)	✓ (2)	u	✓ (2)	✓ (2)	✓ (2)	✓ (2)
40	✓ (2)	✓ (2)	✓ (2)	✓ (2)	u	✓ (2)	✓ (2)	✓ (2)	✓ (2)
50	✓ (2)	✓ (2)	✓ (2)	✓ (2)	u	✓ (2)	✓ (2)	✓ (2)	✓ (2)
63	✓ (2)	✓ (2)	✓ (2)	✓ (2)	u	✓ (2)	✓ (2)	✓ (2)	✓ (2)
80	✓ (2)	✓ (2)	✓ (2)	✓ (2)	✓ (2)	✓ (2)	✓ (2)	✓ (2)	✓ (2)
100	✓ (2)	✓ (2)	✓ (2)	✓ (2)	✓ (2)	✓ (2)	✓ (2)	✓ (2)	✓ (2)

Operating Range

Auto switch model	Bore size [mm]							
	20	25	32	40	50	63	80	100
D-M9m(V) D-M9mW(V) D-M9mA(V)	5	4.5	5	4	4.5	5	10	8
D-A9m(V)	9	9	9	9	9	10.5	14	10.5
D-P3DW	5	5.5	5.5	5.5	5.5	6.5	9	7

* Values which include hysteresis are for guideline purposes only, they are not a guarantee (assuming approximately $\pm 30\%$ dispersion) and may change substantially depending on the ambient environment.

Minimum Stroke for Auto Switch Mounting

Bore size [mm]	Auto switch model Number of auto switches	[mm]							
		D-M9m	D-M9mW D-M9mA	D-M9mV	D-M9mWV	D-M9mAV	D-A9m	D-A9mV	D-P3DW
20	2	15	15	5	10	10	10	10	15
	1	15	15	5	5	10	10	5	15
25	2	10	15	5	10	10	10	10	15
	1	10	15	5	5	10	10	5	15
32, 40, 50	2	10	15	5	10	10	10	10	10
	1	10	15	5	5	10	10	5	10
63	2	10	15	5	10	10	10	10	10
	1	5	15	5	5	10	5	5	10
80, 100	2	15	15	5	10	10	10	10	10
	1	15	15	5	5	10	10	5	10

Other than the applicable auto switches listed in "How to Order", the following auto switches are mountable.

- * Normally closed (NC = b contact) solid state auto switches (D-F9G/F9H) and solid state auto switch D-F8 type are also available. For details, refer to Best Pneumatics.
- * With pre-wired connector is also available for solid state auto switches. For details, refer to the **Web Catalog** or Best Pneumatics.

Mounting of Auto Switch/Direct Mounting Type

To mount auto switches, follow the instruction illustrated below.

<Applicable auto switch>

Solid state D-M9m(V)
 D-M9mW(V)
 D-M9mA(V)
 Reed D-A9m(V)

ø20 to ø100

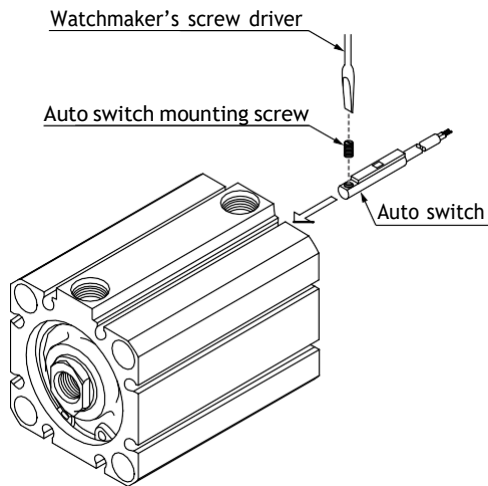

Use a watchmaker's screwdriver with a handle diameter of 5 to 6 mm when tightening the auto switch mounting screw.

Tightening Torque of Auto Switch

Mounting Screws [N·m]	
Auto switch model	Tightening torque
D-M9m(V) D-M9mW(V) D-M9mA(V)	0.05 to 0.15
D-A9m(V)	0.10 to 0.20

<Applicable auto switch>

Solid state D-P3DW

ø20 to ø100

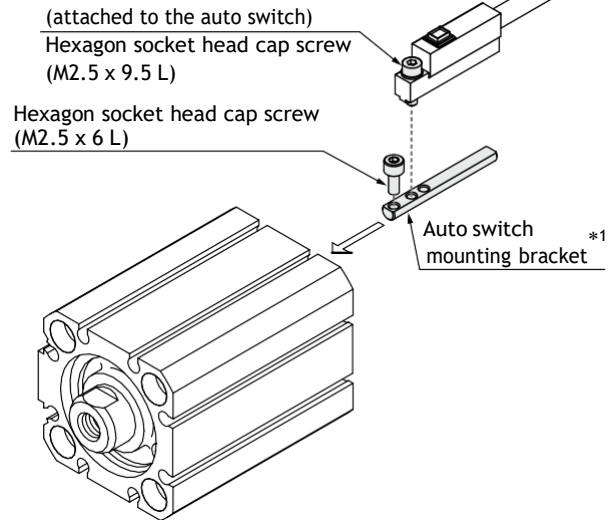

*1 When the auto switch mounting bracket is ordered by its part number, it includes all the bracket and screws in the above chart.

Applicable auto switch	Auto switch mounting bracket part no.
D-P3DW	BQ6-032S

- q Fix the auto switch and the auto switch mounting bracket temporarily by tightening the hexagon socket head cap screw (M2.5 x 9.5 L) 1 to 2 turns.
- w Insert the temporarily tightened mounting bracket into the mating groove of the cylinder tube, and slide the auto switch onto the cylinder tube through the groove.
 When inserting into the mating groove of the cylinder/actuator, please hold the rear end of the auto switch (lead wire side) and the rear end of the auto switch mounting bracket together whilst working.
- e Check the detecting position of the auto switch and fix the auto switch firmly with the hexagon socket head cap screw (M2.5 x 6 L, M2.5 x 9.5 L).*2
- r If the detecting position is changed, go back to step w.

*2 The hexagon socket head cap screw (M2.5 x 6 L) is used to fix the mounting bracket and cylinder tube.
 This enables the replacement of the auto switch without adjusting the auto switch position.

* Ensure that the auto switch is covered with the mating groove to protect the auto switch.

* The torque for tightening the hexagon socket head cap screw (M2.5 x 6 L, M2.5 x 9.5 L) is 0.2 to 0.3 N·m.

* Tighten the hexagon socket head cap screws evenly.

C85
C85W
C85-S/T
C85K
C85K-S/T
C85R
C75
C75W
C75-S/T
C75K
C75K-S/T
C75R
CP96
CP96K
C96
C96K
C96Y
C55
Auto Switch
Made to Order
Related Products

Prior to Use

Auto Switch Connections and Examples

Sink Input Specifications

3-wire, NPN

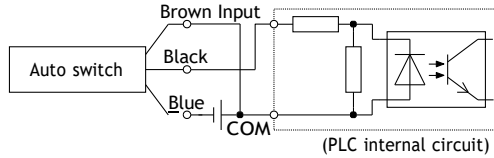

2-wire

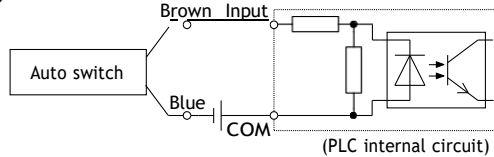

Source Input Specifications

3-wire, PNP

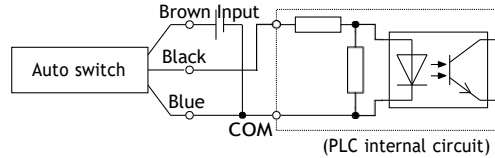

2-wire

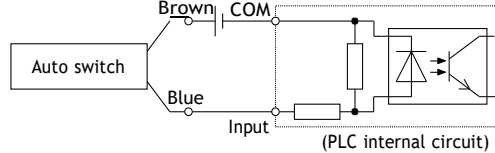

Connect according to the applicable PLC input specifications, as the connection method will vary depending on the PLC input specifications.

Examples of AND (Series) and OR (Parallel) Connections

* When using solid state auto switches, ensure the application is set up so the signals for the first 50 ms are invalid.

3-wire AND connection for NPN output

(Using relays)

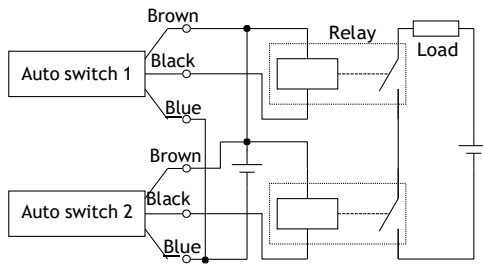

(Performed with auto switches only)

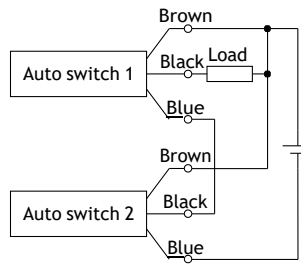

3-wire OR connection for NPN output

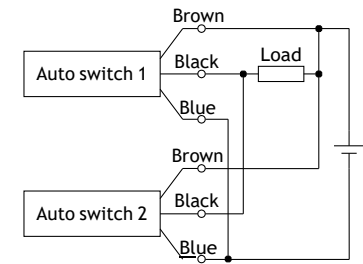

3-wire AND connection for PNP output

(Using relays)

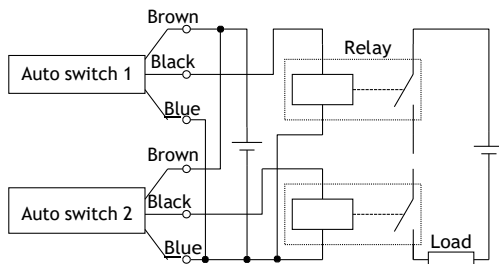

(Performed with auto switches only)

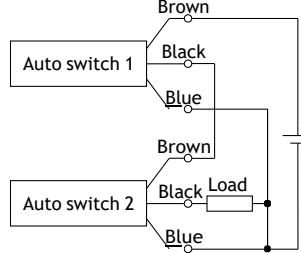

3-wire OR connection for PNP output

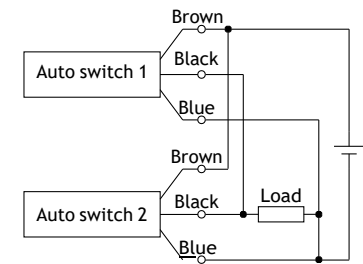

2-wire AND connection

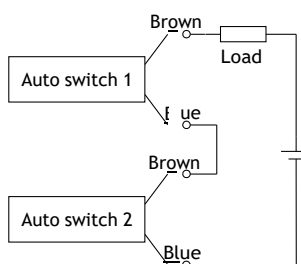

When two auto switches are connected in series, a load may malfunction because the load voltage will decline when in the ON state.

The indicator lights will light up when both of the auto switches are in the ON state. Auto switches with a load voltage less than 20 V cannot be used.

$$\begin{aligned} \text{Load voltage at ON} &= \text{Power supply voltage} - \\ &\quad \text{Residual voltage} \times 2 \text{ pcs.} \\ &= 24 \text{ V} - 4 \text{ V} \times 2 \text{ pcs.} \\ &= 16 \text{ V} \end{aligned}$$

Example: Power supply is 24 VDC
Internal voltage drop in auto switch is 4 V.

2-wire OR connection

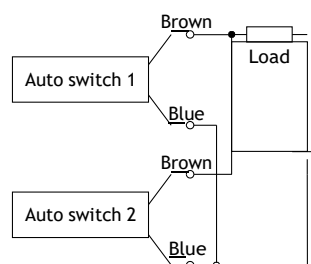

(Solid state)
When two auto switches are connected in parallel, malfunction may occur because the load voltage will increase when in the OFF state.

(Reed)
Because there is no current leakage, the load voltage will not increase when turned OFF. However, depending on the number of auto switches in the ON state, the indicator lights may sometimes grow dim or not light up, due to the dispersion and reduction of the current flowing to the auto switches.

$$\begin{aligned} \text{Load voltage at OFF} &= \text{Leakage current} \times 2 \text{ pcs.} \times \\ &\quad \text{Load impedance} \\ &= 1 \text{ mA} \times 2 \text{ pcs.} \times 3 \text{ k}\Omega \\ &= 6 \text{ V} \end{aligned}$$

Example: Load impedance is 3 k Ω .
Leakage current from auto switch is 1 mA.

C55 Series Simple Specials

The following changes are dealt with through the Simple Specials System.

For details, refer to the Simple Specials in the Web Catalog.
<http://www.smcworld.com>

Symbol

1 Change of Rod End Shape

-XA1 to 23, -XA26 to 30

Applicable Series

Series	Description	Action	Bore size	Symbol for change of rod end shape
C55	Standard type	Double acting, Single rod	20, 25	XA1, XA2, XA6 XA7, XA11, XA17 XA18
			32 to 100	XA1 to 23, XA26 to 30

⚠ Precautions

- SMC will make appropriate arrangements if no dimension, tolerance, or finish instructions are given in the diagram.
- Standard dimensions marked with "*" will be as follows to the rod diameter (D). Enter any special dimension you require.
 $D \leq 6 \rightarrow D-1 \text{ mm}$ $6 < D \leq 25 \rightarrow D-2 \text{ mm}$ $D > 25 \rightarrow D-4 \text{ mm}$
- In the case of the double rod type and single acting retraction type, enter the dimensions when the rod is retracted.
- Only one side of a double rod can be manufactured.

Symbol: A1 	Symbol: A2 	Symbol: A3 	Symbol: A4 	Symbol: A5
Symbol: A6 	Symbol: A7 	Symbol: A8 	Symbol: A9 	Symbol: A10
Symbol: A11 	Symbol: A12 	Symbol: A13 	Symbol: A14 	Symbol: A15
Symbol: A16 	Symbol: A17 	Symbol: A18 	Symbol: A19 	Symbol: A20
Symbol: A21 	Symbol: A22 	Symbol: A23 	Symbol: A26 	Symbol: A27
Symbol: A28 	Symbol: A29 	Symbol: A30 		

C55 Series

Made to Order

Please contact SMC for detailed dimensions, specifications, and lead times.



1 Made of Stainless Steel

Symbol
-XC6

Suitable for the cases it is likely to generate rust by being immersed in the water and corrosion.

How to Order

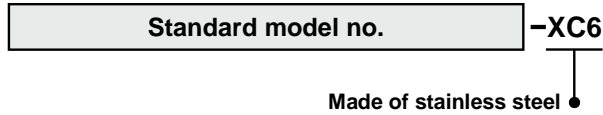

Specifications

Parts changed to stainless steel	Piston rod, Retaining ring, Rod end nut (Male thread only)
Specifications other than above and external dimensions	Same as standard