

G-20 SERIES



Dimensions



G-20R, G-20DE, G-20N, G-20NE, G-20P, G-20PE / G-20R-QD, G-20DE-QD, G-20N-QD, G-20NE-QD, G-20P-QD, G-20PE-QD

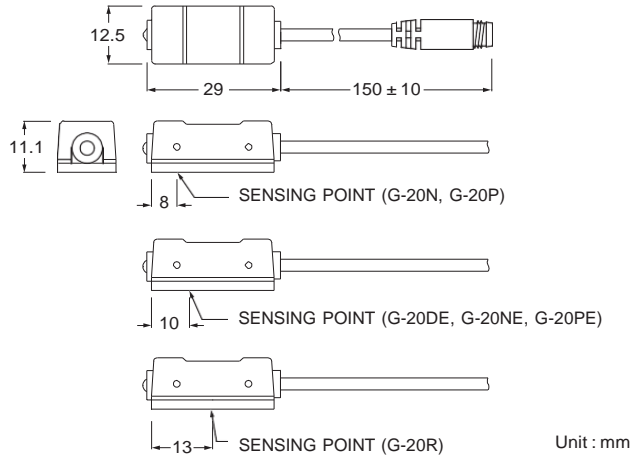

QD Pinout

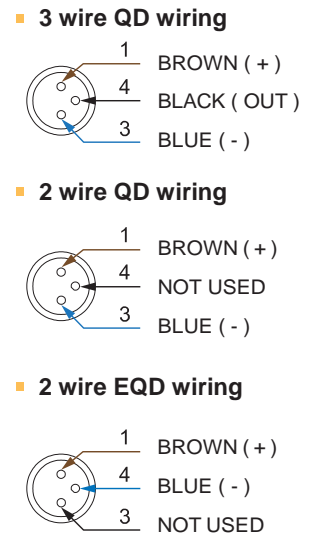

Specifications

MODEL	G-20R	G-20DE	G-20N	G-20NE	G-20P	G-20PE
Connect Diagram						
Characteristics	2-Wire type		3-Wire type			
Wiring Method	2-Wire type		3-Wire type			
Switching Logic	SPST, Normally Open		Solid State Output, Normally Open			
Sensor Type	Reed Switch	-	NPN Current Sinking		PNP Current Sourcing	
Operating Voltage	5 ~ 240 V DC / AC		5 ~ 30 V DC			
Switching Current	100 mA max.	50 mA max.	200 mA max.			
Contact Rating ^{※1}	10 W max.	1.5 W max.	6 W max.			
Current Consumption	-		15 mA @ 24 V DC ^{※6}	6 mA @ 24 V DC max.	15 mA @ 24 V DC ^{※6}	6 mA @ 24 V DC max.
Voltage Drop	3.5 V max.	3.7 V max.	1.5 V max.	0.5 V max.	1.5 V max.	0.5 V max.
Leakage Current	-	0.1 mA (40 uA) max.	0.01 mA max.			
Indicator	Green LED		Red LED		Green LED	
Cable	Ø3.9PVC-24AWG(0.22mm ²)-2 cores	Ø4PVC-24AWG(0.22mm ²)-2 cores	Ø4 PVC - 24 AWG (0.22 mm ²) - 3 cores			
Operating Frequency	200 Hz		1000 Hz max.			
Magnet Requirement ^{※2}	80 Gauss	50 ~ 1000 Gauss	70 Gauss	50 ~ 1000 Gauss	70 Gauss	50 ~ 1000 Gauss
Temperature Range	-10 ~ 70 °C					
Shock ^{※3}	30 G		50 G			
Vibration ^{※4}	9 G					
Enclosure Classification	IEC 60529 IP67					
Protection Circuit ^{※5}	1	3, 4	2, 3, 4	3, 4	2, 3, 4	3, 4

NOTE

※1 : WARNING : Never exceed rating (Watt = Voltage x Amperage). Permanent damage to sensor will occur.

※2 : Measuring standard target : Ø15.5 × Ø8 × 5t (Anisotropy rubber magnet)

※3 : Sin wave / X , Y , Z 3 directions / 3 times each direction / 11 ms each time.

※4 : Double amplitude 1.5 mm / 10 Hz ~ 55 Hz ~ 10 Hz (Sweep 1 min) / X , Y , Z 3 directions / 1 hour each time.

※5 : 1 = None / 2 = Short-circuit / 3 = Power Source Reverse polarity / 4 = Surge Suppression

※6 : TEST CONDITIONS : switch current at 200 mA

Clamps / Bracket

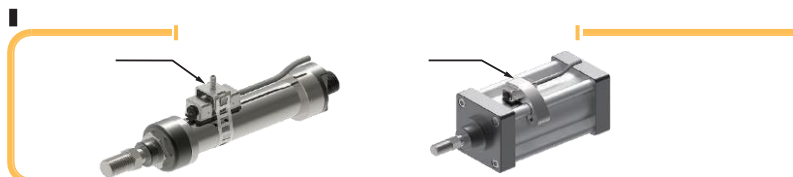

GENTLE AUTOMATIC SOLUTION SDN BHD

No.36, Jalan Industri USJ 1/13, Taman Perindustrian USJ 1, 47600 Subang Jaya, Selangor.

TEL: 603 - 8023 7743 / 8743

FAX: 603 - 8023 9743

Email : sales@gentle.com.my