

# 2-Color Indication Type Reed Auto Switch Band Mounting Style D-B59W



## Grommet

The proper operating range can be determined by the color of the light.  
(Red → Green ← Red)



## Auto Switch Internal Circuit

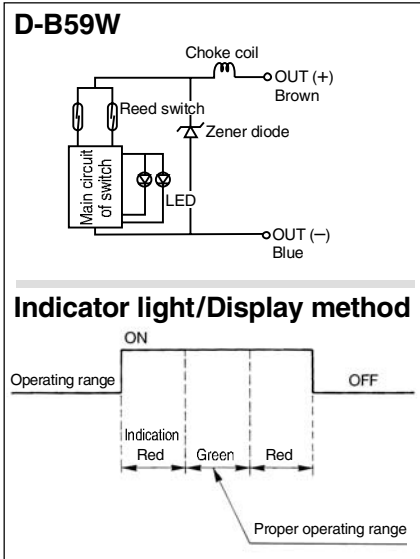

## Auto Switch Specifications

PLC: Programmable Logic Controller

D-B59W (With indicator light)	
Auto switch model	<b>D-B59W</b>
Applicable load	Relay, PLC
Load voltage	24 VDC
Load current range <sup>(3)</sup>	5 to 40 mA
Contact protection circuit	Built-in
Internal voltage drop	4 V or less
Indicator light	Operating range ..... Red LED illuminates. Proper operating range ..... Green LED illuminates.
Standard	CE marking

• Lead wires — Oilproof heavy-duty vinyl cord,  $\phi 4$ , 0.3 mm<sup>2</sup>, 2 cores (Brown, Blue), 0.5 m  
Note 1) Refer to page 1272 for reed auto switch common specifications.

Note 2) Refer to page 1272 for lead wire lengths.

Note 3) Under 5 mA, the strength of the indicator light is poor. In some cases, visibility of the indicator light will not be possible where the output signal is less than 2.5 mA. However, there is no problem in terms of contact output, when an output signal exceeds 1 mA or more.

## Mass

(g)

Auto switch model		<b>D-B59W</b>
Lead wire length (m)	0.5	20
	3	76
	5	—

## Dimensions

(mm)

