

Magnetic Field Resistant 2-Color Indication Type Solid State Auto Switch

D-P3DWSC/D-P3DWSE (Electrical Entry: Pre-wired connector)

- It is possible to use in an environment which generates a magnetic field disturbance (AC magnetic field).
- The proper operating range can be determined by the color of the light. (Red → Green ← Red)

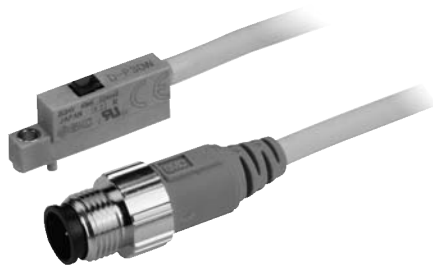

⚠ Caution

Precautions

For single-phase AC welding machines If it is used for current inverter welders (including rectifying type) and condenser type welders, the magnetic field resistance is reduced. Please contact SMC regarding the performance.

Auto Switch Internal Circuit

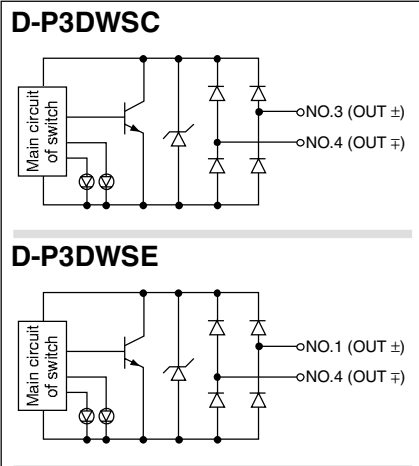

Indicator light/Display method

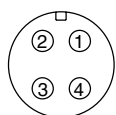
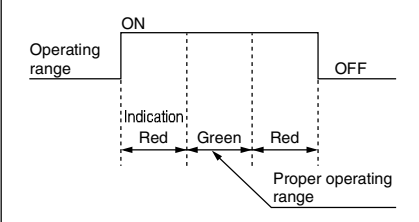

Connector pin

Auto Switch Specifications

PLC: Programmable Logic Controller

D-P3DWSC/E (With indicator light)		
Auto switch model	D-P3DWSC	D-P3DWSE
Applicable load	24 VDC relay, PLC	
Load voltage	24 VDC (20 to 28 VDC)	
Load current	6 to 40 mA or less	
Internal voltage drop	5 V or less	
Leakage current	1 mA or less at 24 VDC	
Operating time	40 ms or less	
Indicator light	Operating range Red LED illuminates. Proper operating range Green LED illuminates.	
Standard	CE marking, UL (CSA), RoHS	

- Lead wire — Oilproof heavy-duty vinyl cable, $\phi 4.8$, 0.5 mm², 2 cores
- Impact resistance — Switch: 1000 m/s², Connector: 300 m/s²
- Insulation resistance — 50 M Ω or more at 500 VDC Mega (between lead wire and case)
- Withstand voltage — 1000 VAC for 1 minute (between lead wire and case)
- Ambient temperature — -10 to 60°C
- Enclosure — IEC60529 standard IP67
- Polarity: Non-polar

Magnetic Field Resistance

If the current of the AC welding machine is 16000 A or lower, the auto switch can be used, even if the distance between the welding conductor (gun cable) and the cylinder/actuator or auto switch is 0 mm. Please contact SMC when the AC welding current exceeds 16000 A.

Mass

(g)

Auto switch model	D-P3DWSC	D-P3DWSE
Lead wire length (m)	0.3	23

Dimensions

(mm)

Body

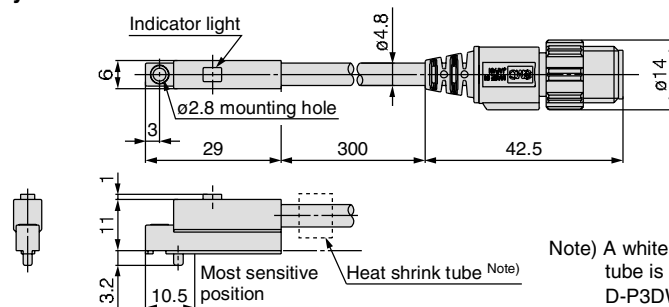

Auto switch mounting bracket (For round groove mounting: BQ3-032S)

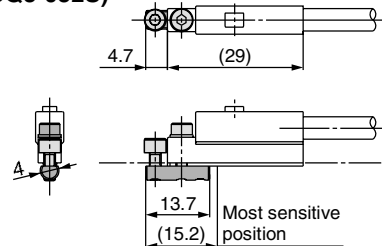

Auto switch mounting bracket (For square groove mounting: BMG5-025S)

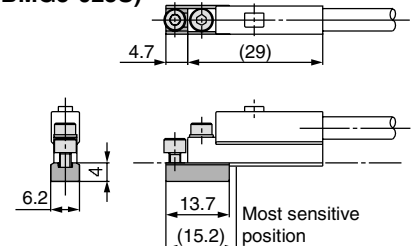

* When the auto switch is ordered on its own, the auto switch mounting bracket is not enclosed. In that case, please order it separately.