

# Reed Auto Switch Direct Mounting Type

## D-E73A/D-E76A/D-E80A



### Grommet



### ⚠ Caution

#### Precautions

Do not drop or bump the auto switch while handling it as it may result in the auto switch breaking.

### Auto Switch Specifications

PLC: Programmable Logic Controller

D-E7□A (With indicator light)			
Auto switch model		D-E73A	D-E76A
Applicable load		Relay, PLC	
Load voltage		24 VDC <sup>(1)</sup>	100 VAC
Max. load current and load current range <sup>(2)</sup>		5 to 40 mA	5 to 20 mA
Internal circuit*		e	t
Contact protection circuit		None	
Internal voltage drop		2.4 V or less	0.8 V or less
Indicator light		Red LED illuminates when turned ON.	
Standard		CE/UKCA marking	
D-E80A (Without indicator light)			
Auto switch model		D-E80A	
Applicable load		Relay, PLC, IC circuit	
Load voltage		24 VDC <sup>(1)</sup> or less	100 VDC
Maximum load current		50 mA	20 mA
Internal circuit*		r	
Contact protection circuit		None	
Internal resistance		1 $\Omega$ or less (Including lead wire length of 3 m)	
Standard		CE/UKCA marking	

### Oilproof Heavy-duty Lead Wire Specifications

Auto switch model		D-E73A	D-E76A	D-E80A
Sheath	Outside diameter [mm]	$\phi$ 3.4		
Insulator	Number of cores	2 cores (Brown/Blue)	3 cores (Brown/Blue/Black)	2 cores (Brown/Blue)
	Outside diameter [mm]	$\phi$ 1.1		
Conductor	Effective area [mm <sup>2</sup> ]	0.2		
	Strand diameter [mm]	$\phi$ 0.08		
Lead wire number of strands (Reference)		21		

\*Refer to the applicable internal circuit diagram (numbers q to u) on page 1587.

Note 1) Refer to page 1584 for reed auto switch common specifications.

Note 2) Refer to page 1584 for lead wire lengths.

Note 3) Under 5 mA, the strength of the indicator light is poor. In some cases, visibility of the indicator light will not be possible where the output signal is less than 2.5 mA. However, there is no problem in terms of contact output, when an output signal exceeds 1 mA or more.

Note 4) The auto switches can operate at 12 VDC, but consider the internal voltage drop of the auto switch described in Reed Auto Switch Precautions on page 12.

### Weight

(g)

Auto switch model		D-E73A	D-E76A	D-E80A
Lead wire length	0.5 m (Nil)	10	11	10
	3 m (L)	47	55	47

### Dimensions

(mm)

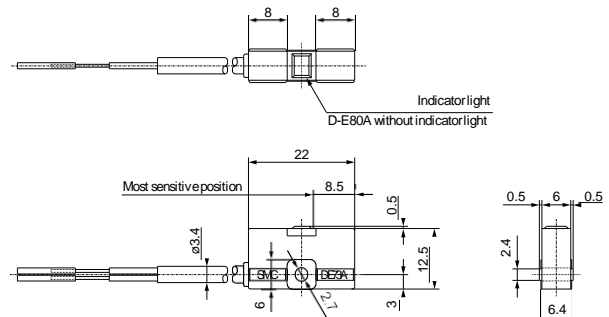

### Gentle Automatic Solution Sdn Bhd

No.36, Jalan Industri USJ 1/13, Taman Perindustrian USJ 1, 47600 Subang Jaya, Selangor.  
TEL: 603-8023 7743 / 8743 FAX: 603-8023 9743

sales@gentle.com.my

0122738827

www.gentle.com.my

waze.to/tr/hw28325k63