

2-Color Indicator Solid State Auto Switch Band Mounting Type

D-G59W/D-G5PW/D-K59W



Grommet

The proper operating range can be determined by the color of the light.
(Red → Green ← Red)



Dimensions

(mm)

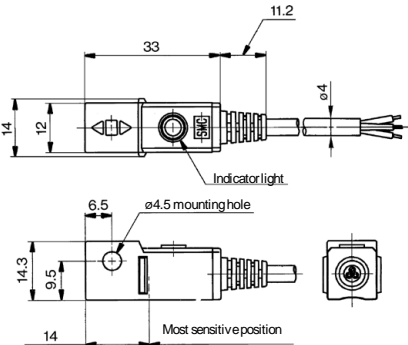

Auto Switch Specifications

PLC: Programmable Logic Controller

D-G5□W, D-K59W (With indicator light)			
Auto switch model	D-G59W	D-G5PW	D-K59W
Wiring type	3-wire		2-wire
Output type	NPN	PNP	—
Applicable load	IC circuit, Relay, PLC		24 VDC Relay, PLC
Power supply voltage	5, 12, 24 VDC (4.5 to 28 VDC)		—
Current consumption	10 mA or less		—
Load voltage	28 VDC or less	—	24 VDC (10 to 28 VDC)
Load current	40 mA or less	80 mA or less	5 to 40 mA
Internal voltage drop	1.5 V or less (0.8 V or less at 10 mA load current)	0.8 V or less	4 V or less
Leakage current	100 μA or less at 24 VDC		0.8 mA or less at 24 VDC
Indicator light	Operating range Red LED illuminates. Proper operating range Green LED illuminates.		
Standard	CE/UKCA marking		

Oilproof Heavy-duty Lead Wire Specifications

Auto switch model		D-G59W	D-G5PW	D-K59W
Sheath	Outside diameter [mm]	ø4		
Insulator	Number of cores	3 cores (Brown/Blue/Black)		2 cores (Brown/Blue)
	Outside diameter [mm]	ø1.22		
Conductor	Effective area [mm ²]	0.3		
	Strand diameter [mm]	Solid state auto switch common specifications and wire lengths.		
Minimum bending radius [mm] (Reference value)	24			

Weight

(g)

Auto switch model		D-G59W	D-G5PW	D-K59W
Lead wire length	0.5 m (Nil)	20	18	18
	3 m (L)	78	68	68
	5 m (Z)	124	108	108

