

Solid State Auto Switch Band Mounting Type D-H7A1/D-H7A2/D-H7B



Grommet



Auto Switch Specifications

PLC: Programmable Logic Controller

D-H7 □ (With indicator light)			
Auto switch model	D-H7A1	D-H7A2	D-H7B
Wiring type	3-wire		2-wire
Output type	NPN	PNP	—
Applicable load	IC circuit, Relay, PLC		24 VDC Relay, PLC
Power supply voltage	5, 12, 24 VDC (4.5 to 28 VDC)		—
Current consumption	10 mA or less		—
Load voltage	28 VDC or less	—	24 VDC (10 to 28 VDC)
Load current	40 mA or less	80 mA or less	5 to 40 mA
Internal voltage drop	1.5 V or less (0.8 V or less at 10 mA load current)	0.8 V or less	4 V or less
Leakage current	100 μA or less at 24 VDC		0.8 mA or less at 24 VDC
Indicator light	Red LED illuminates when turned ON.		
Standard	CE/UKCA marking		

Oilproof Heavy-duty Lead Wire Specifications

Auto switch model		D-H7A1	D-H7A2	D-H7B
Sheath	Outside diameter [mm]	ø3.4		
Insulator	Number of cores	3 cores (Brown/Blue/Black)		2 cores (Brown/Blue)
	Outside diameter [mm]	ø1.1		
Conductor	Effective area [mm ²]	0.2		
	Strand diameter [mm]	Id state auto switch common specification		
Minimum bending radius [mm] (Reference value)	21			

Weight

(g)

Auto switch model		D-H7A1	D-H7A2	D-H7B
Lead wire length	0.5 m (Nil)	13		11
	3 m (L)	57		50
	5 m (Z)	92		81

Dimensions

(mm)

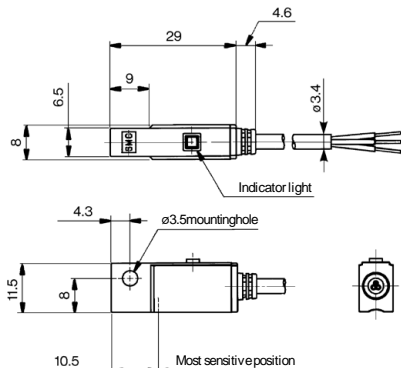

Gentle Automatic Solution Sdn Bhd

No.36, Jalan Industri USJ 1/13, Taman Perindustrian USJ 1, 47600 Subang Jaya, Selangor.
TEL: 603-8023 7743 / 8743 FAX: 603-8023 9743

sales@gentle.com.my

0122738827

www.gentle.com.my

waze.to/tr/hw28325k63

