

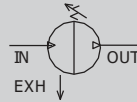

Air booster(Air booster)

ABP2-HP1 Series

JISCode



Specifications

Item	ABP2-HP1
Working fluid	Compressed air
Max. working pressure MPa	0.99
Min. working pressure MPa	0.2
Set pressure MPa	From a primary pressure of +0.1MPa to twice the primary pressure (max. 0.99MPa)
Proof pressure MPa	1.5
Flow rate m ³ /min(ANR)	Refer to the flow characteristics in the graph on the right
Boosting ratio	Max. twice (or equivalent)
Ambient temperature°C	0 to 50 (no freezing)
Lubrication	Not available
Port size	Rc1/4 (bottom, back Rc1/8)
Weight kg	2.0
Durability [Example of model No.]	10 million cycles(Nominal) (Refer to page 2)

ABP2-02R-GSN-HP1

Model: Air booster

- A Body piping thread: Rc thread
- B Pressure gauge option: Pressure gauge (2 included)
- C Silencer option: Silencer (2 pcs. included)
- D Bracket option: None

How to order

ABP2-02R-N-N-N-HP1

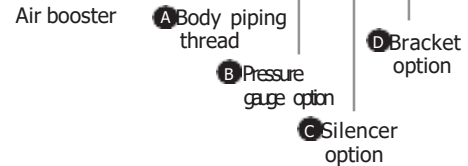

Code	Description
R	Rc thread
N	NPT thread (made to order) *1
G	G thread (made to order) *1
N	No
G	Pressure gauge (2 included)
N	No
S	Silencer (2 pcs. included)
H	High performance silencer (2 pcs. included)
N	No
B	Foot bracket (2 included)
T	Tank mounting base (included)

*1: IN, OUT gauge port, and EXH port are Rc threads

Functions

- Primary pressure from IN passes through the check valve on IN side, and flows into booster chambers A and B. The primary pressure passes through the pressure adjustment section and switching valve, and flows into the driving chamber A. The piston moves to the left due to the pressure of the driving chamber A. Air in booster chamber A is compressed, passes through the check valve on the OUT side, and goes to the OUT side.
- When the piston reaches the stroke end, the changeover switch will be pushed, causing compressed air to be supplied to the switching valve pilot chamber and causing the switching valve to change over. Then the air in drive chamber A is exhausted, and the air is delivered to drive chamber B.
- Therefore, the piston moves to the right and air in booster chamber B is compressed, then passes through the check valve at the OUT side and moves OUT.
- If the above operations are repeated, pressure will be increased on the OUT side. Feedback pressure is transmitted to the pressure adjustment section due to the OUT side pressure, and boosting is continued until the pressure adjustment spring pressure is balanced.

Internal air circuit diagram

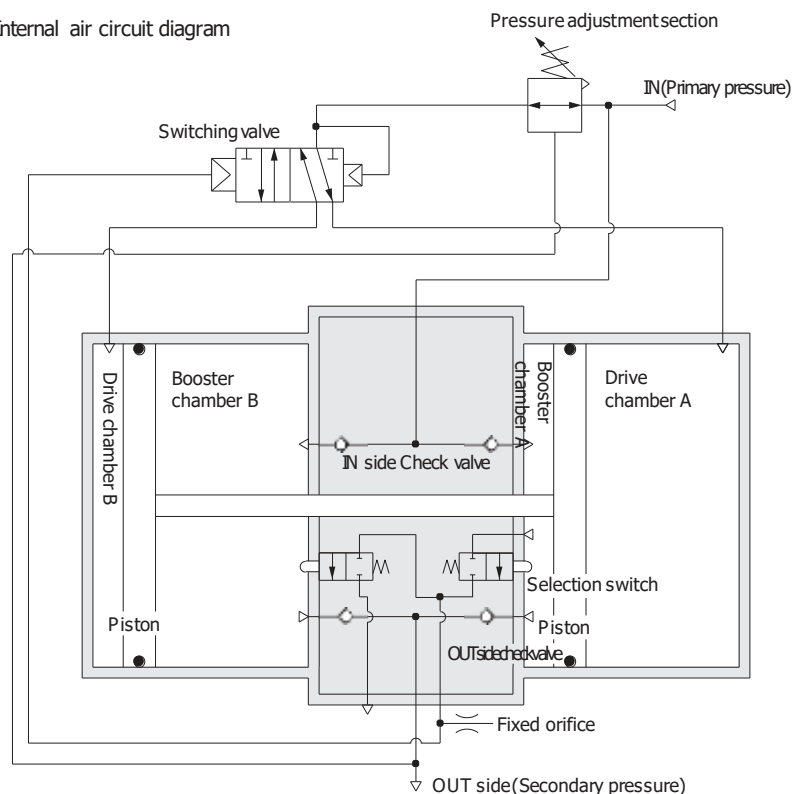

Flow characteristics

(with the 5 L air tank, equivalent to double the pressure increase)

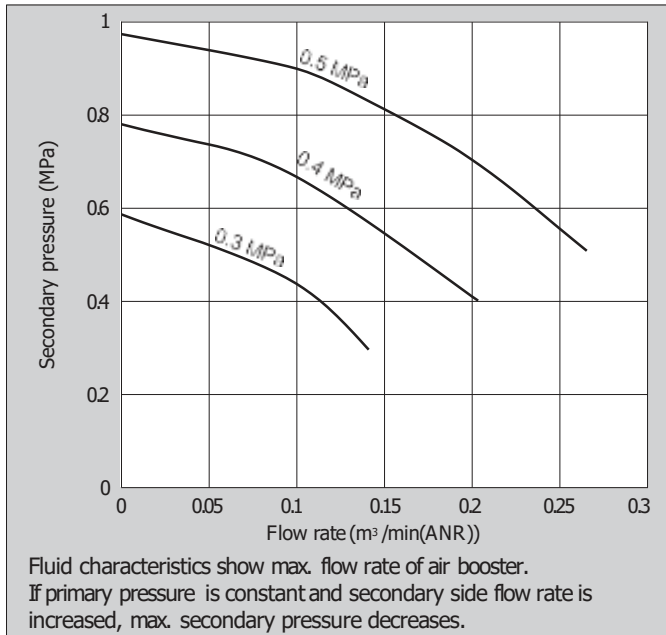

Note: Air booster needs approx. twice secondary side flow rate (max.) for primary side due to structure.
Confirm that the instantaneous flow rate is within the curve.

Pressure characteristics

(Setting: Primary pressure: 0.7MPa Secondary pressure: 0.99MPa Flowrate: 0.02m³/min(ANR))

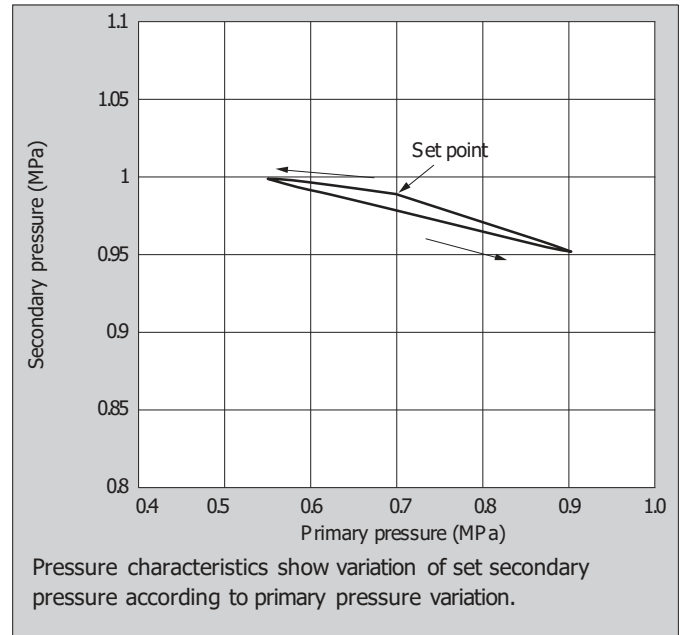

Filling characteristics (when the boosting ratio is equivalent to twice)

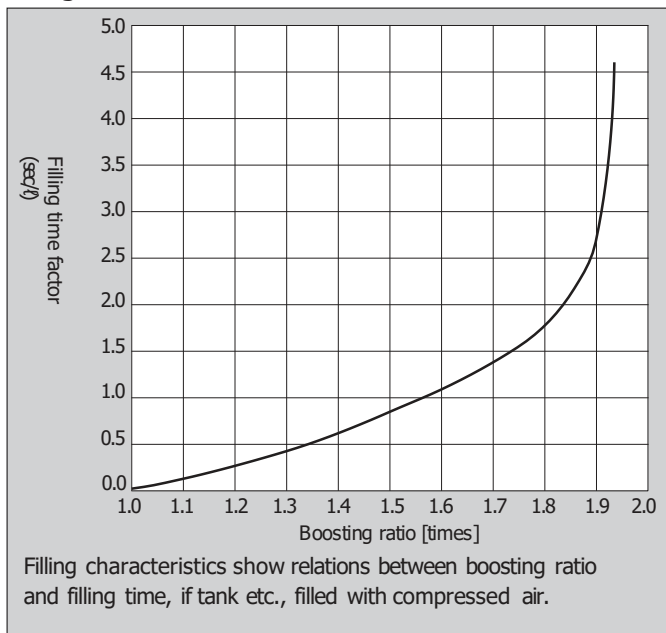

The time required to fill the tank with air can be calculated as follows. With the primary side pressure P_0 , inner tank pressure before filling P_1 , inner tank pressure after filling P_2 , pre-filling ratio between primary side pressure and inner tank pressure k_1 , and post-filling ratio between primary side pressure and inner tank pressure k_2 , the formula will be $k_1 = \frac{P_1}{P_0}$, $k_2 = \frac{P_2}{P_0}$. Calculate k_1 and k_2 , find the filling time factors t_1 and t_2 at the boosting ratio points k_1 and k_2 in the graph and substitute the values into $t = (t_2 - t_1)A$ to obtain the filling time t of the tank capacity A .

Pulsation

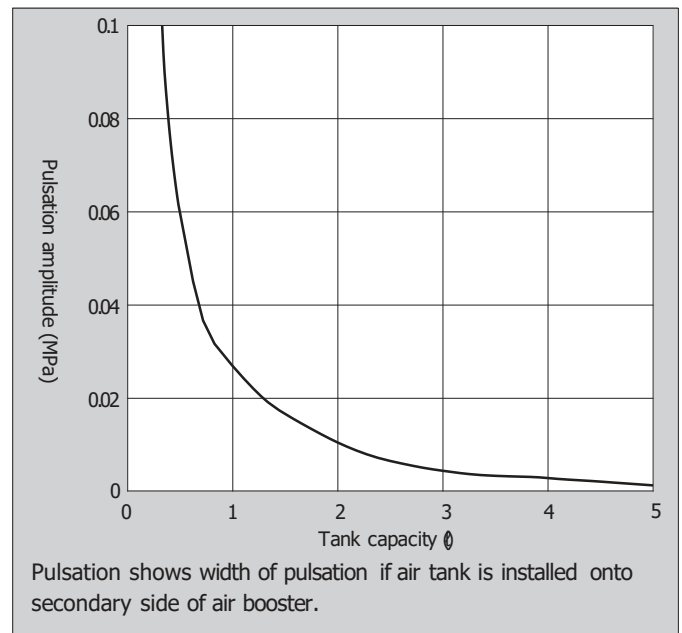

Formula for air booster operational cycle

$$N = \frac{Q \times 10^3}{0.95P + 0.096}$$

N: Operational cycle
Q: Required flow rate (m³/min(ANR))
P: Primary pressure (MPa)

Formula for air booster service life

The nominal life of the operational cycle is, in 10 million cycles

$$T = \frac{10,000,000}{N \times 60}$$

T: Service life (Time)

The characteristics above are typical examples, not guaranteed values.

ABP2-HP1 Series

Internal structure

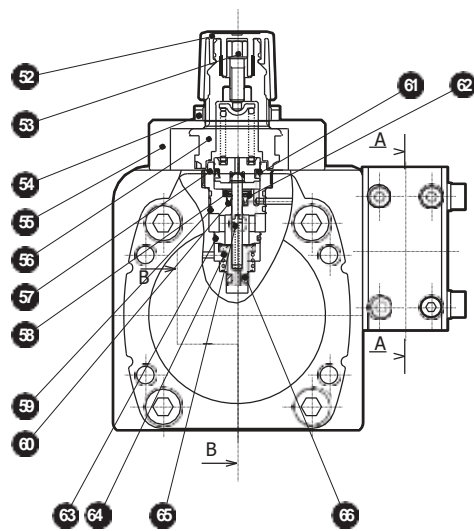
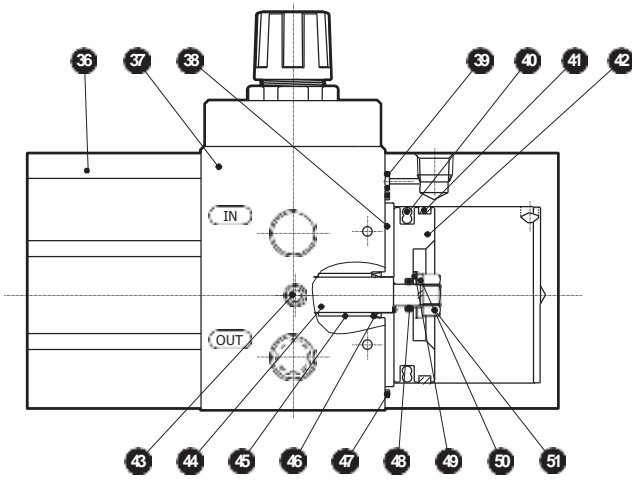
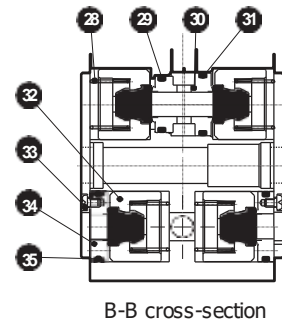
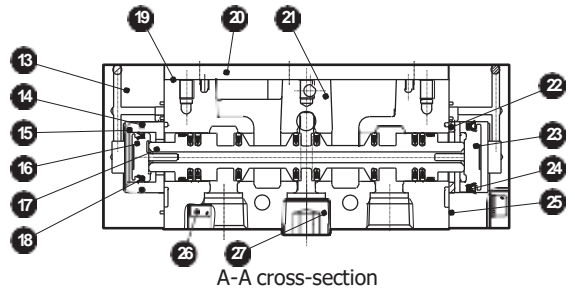
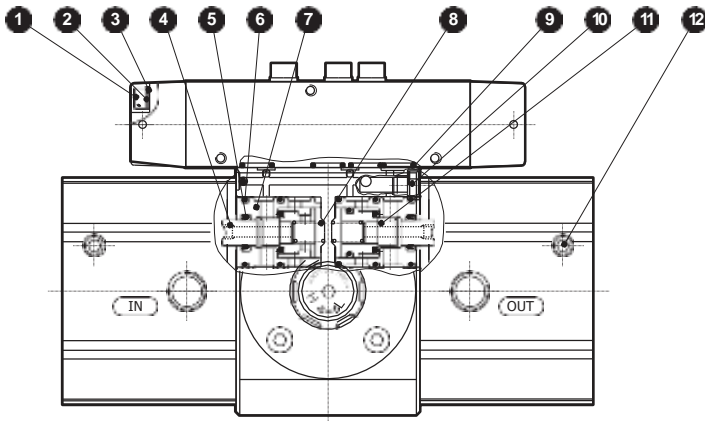

Parts list

Part number	Part name	Material	Part number	Part name	Material
1	Hexagon socket head cap screw	Stainless steel	34	Valve seat	Aluminum alloy
2	Spring washer	Stainless steel	35	O-ring	Nitrile rubber
3	Flat washer	Stainless steel	36	Cylinder body	Aluminum alloy
4	Valve bar	Stainless steel	37	Body	Aluminum alloy
5	Packing	Nitrile rubber	38	Side plate	Aluminum alloy
6	O-ring	Nitrile rubber	39	O-ring	Nitrile rubber
7	Detection valve body	Aluminum alloy	40	Packing	Nitrile rubber
8	Spring	Steel	41	Wear ring	Resin
9	O-ring	Nitrile rubber	42	Piston	Aluminum alloy
10	Fixed orifice	Aluminum alloy	43	Hexagon socket set screw	Stainless steel
11	Valve bar	Stainless steel	44	Piston rod	Stainless steel
12	Hexagon socket set screw	Stainless steel	45	Bush	Oiles drymet
13	Pilot cap	Resin	46	Packing	Nitrile rubber
14	O-ring	Nitrile rubber	47	O-ring	Nitrile rubber
15	Valve piston spacer	Aluminum alloy	48	O-ring	Nitrile rubber
16	Piston	Resin	49	Flat washer	Stainless steel
17	Spool assembly	-	50	Spring washer	Stainless steel
18	Packing	Nitrile rubber	51	Hexagon nut	Stainless steel
19	Adaptor gasket	Nitrile rubber	52	Knob	Resin
20	Adapter	Aluminum alloy	53	Regulator piston assembly	-
21	Valve body	Aluminum alloy	54	Nut	Resin
22	Valve piston spacer	Aluminum alloy	55	Cover holder	Aluminum alloy
23	Piston	Resin	56	Cover	Aluminum alloy
24	Packing	Nitrile rubber	57	Stem holder	Aluminum alloy
25	Gasket	Nitrile rubber	58	CR ring	Stainless steel
26	Hexagon socket head cap screw	Stainless steel	59	O-ring	Nitrile rubber
27	Plug	Steel	60	Packing	Nitrile rubber
28	Spring	Steel	61	Packing	Nitrile rubber
29	O-ring	Nitrile rubber	62	Cap	Stainless steel
30	Valve seat	Aluminum alloy	63	O-ring	Nitrile rubber
31	O-ring	Nitrile rubber	64	Spring	Steel
32	Check valve assembly	-	65	Valve assembly	-
33	Cross recessed pan head machine screw	Stainless steel	66	O-ring	Nitrile rubber

Option 2 parts individual list

Part name	Model No.	Remarks
Bracket	ABP2-02-B	Qty per unit
Base for mounting tank	ABP2-02-T	Hexagon socket head cap screw for tank mounting, O-ring included
Pressure gauge	G29D-6-P15	Pressure gauge x 1
Silencer	SLW-8S-2PC	Silencer x 2
High performance silencer	SLW-8A-H-2PC	Silencer x 2

ABP2-HP1 Series

Dimensions



● ABP2-02-HP1

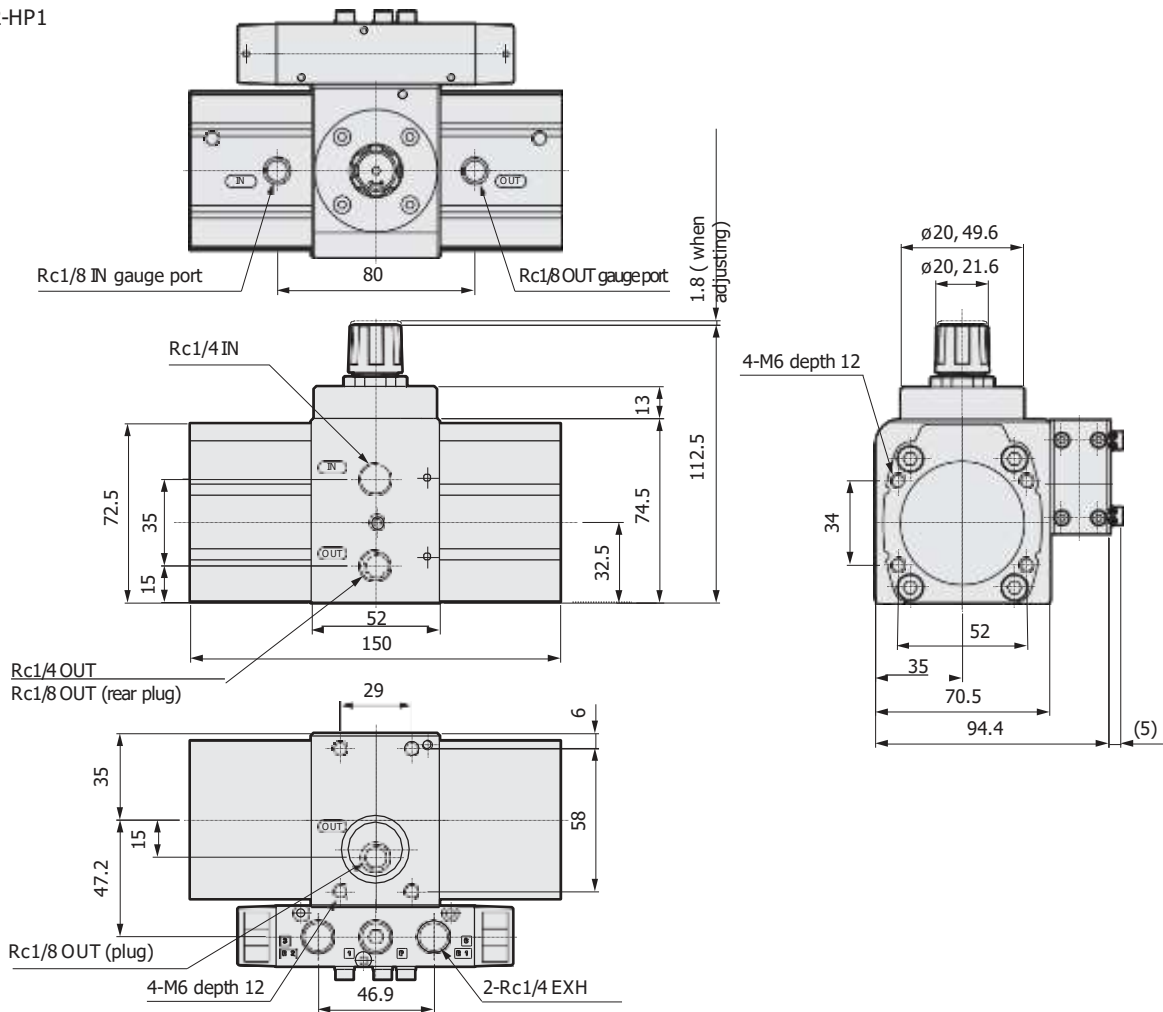

Optional dimensions

● When mounting pressure gauge/silencer/bracket

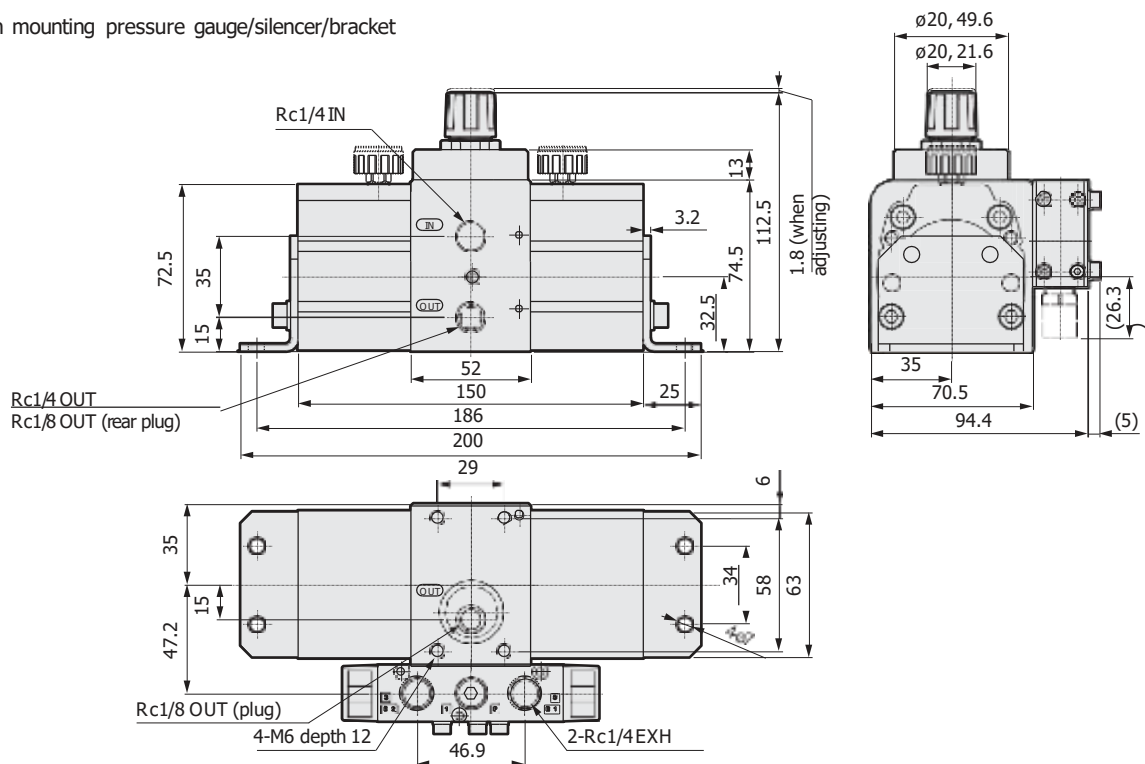

Optional dimensions



- When mounting pressure gauge, high noise reduction silencer and bracket

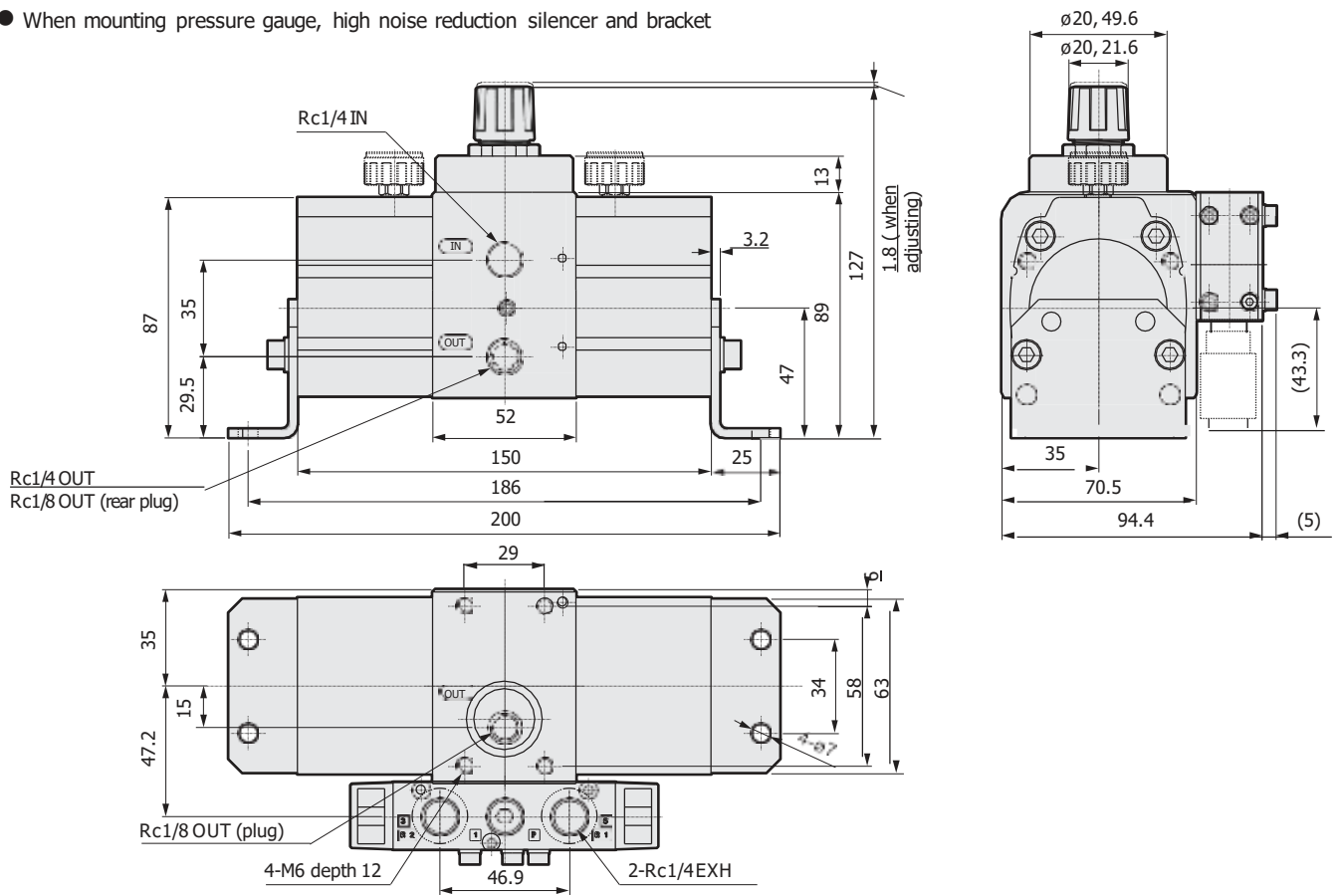

Optional dimensions

- When mounted on the back of the bracket

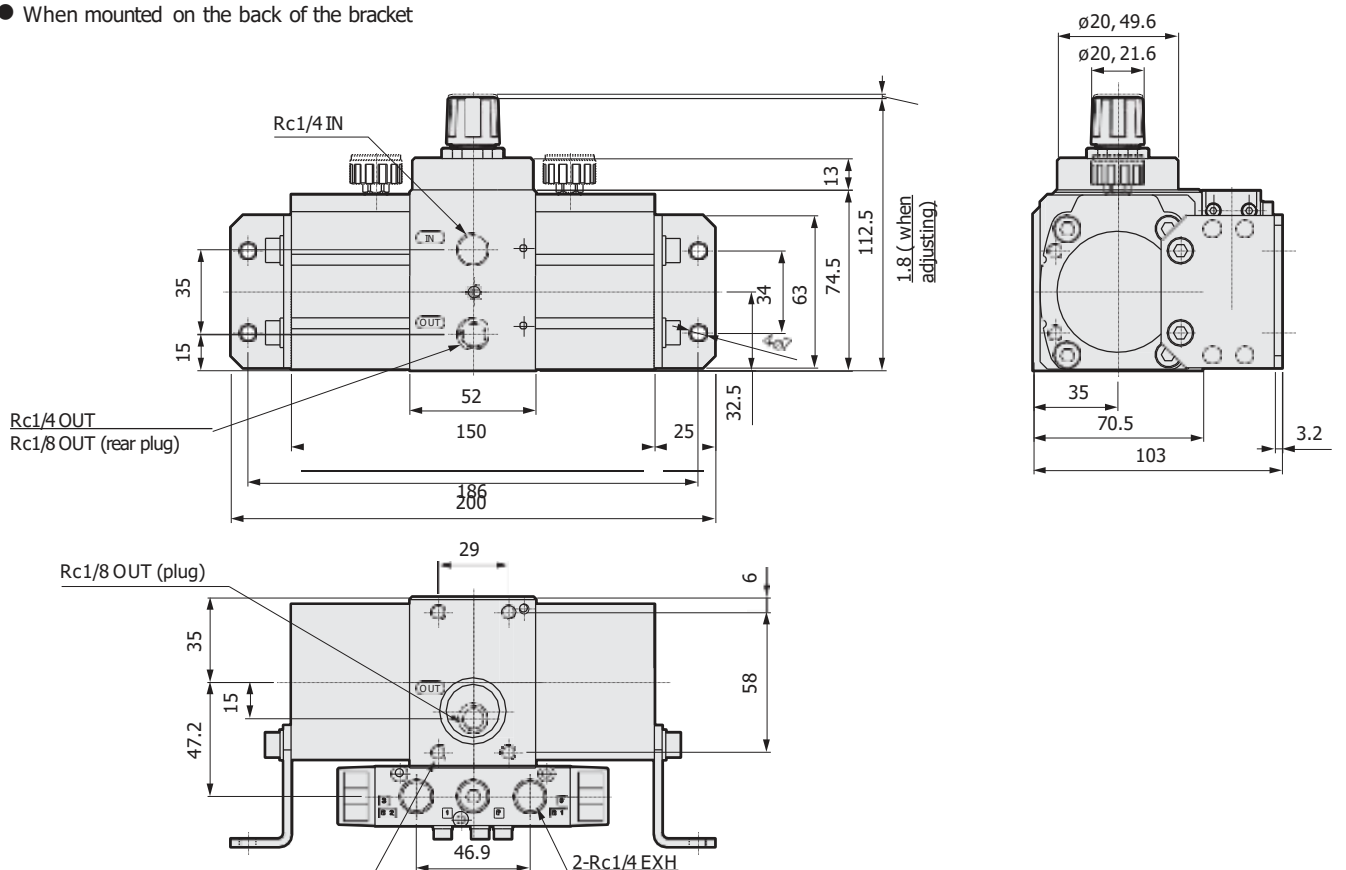

ABP2-HP1 Series

Optional dimensions



- When mounting the tank mounting base

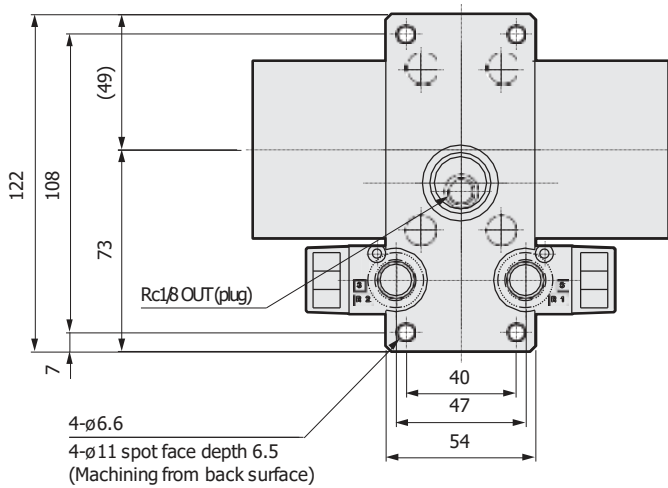
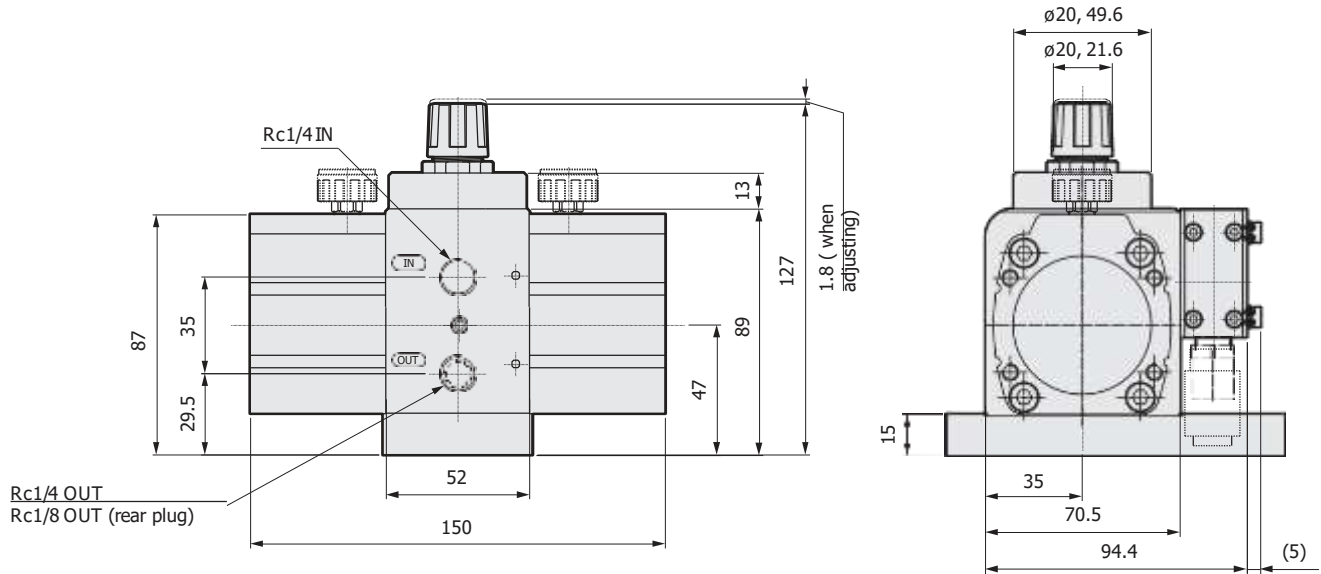

Optional dimensions

- Pressure gauge (G29D-6-P15)

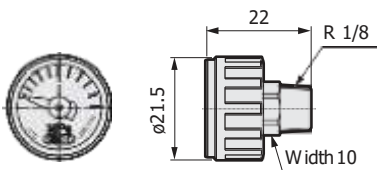

- Silencer (SLW-8S)

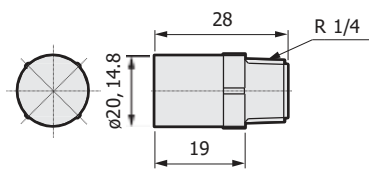

- High noise reduction silencer (SLW-8A-H)

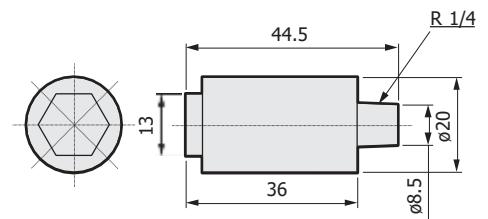



Safety Precautions

Be sure to read this section before use.

When designing and manufacturing a device using CKD products, the manufacturer is obligated to check that device safety mechanism, pneumatic control circuit, or water control circuit and the system operated by electrical control that controls the devices is secured.

It is important to select, use, handle and maintain the product appropriately to ensure that the CKD product is used safely. Observe warnings and precautions to ensure device safety.

Check that device safety is ensured, and manufacture a safe device.

WARNING

- 1** This product is designed and manufactured as a general industrial machine part. It must be handled by an operator having sufficient knowledge and experience.
 - 2** Use this product in accordance with specifications.
This product must be used within its stated specifications. In addition, never modify or additionally machine this product. This product is intended for use in general industrial machinery equipment or parts. It is not intended for use outdoors (except for products with outdoor specifications) or for use under the following conditions or environments.
(Note that this product can be used when CKD is consulted prior to its usage and the customer consents to CKD product specifications. The customer should provide safety measures to avoid danger in the event of problems.)
 - 1** Use for applications requiring safety, including nuclear energy, railways, aircraft, marine vessels, vehicles, medical devices, devices or applications in contact with beverages or foodstuffs, amusement devices, emergency cutoff circuits, press machines, brake circuits, or safety devices or applications.
 - 2** Use for applications where life or assets could be significantly affected, and special safety measures are required.
 - 3** Observe organization standards and regulations, etc., related to the safety of device design and control, etc.
ISO4414, JIS B 8370 (Pneumatics fluid power - General rules and safety requirements for systems and their components)
JFPS2008 (Principles for pneumatic cylinder selection and use)
Including the High Pressure Gas Safety Act, Industrial Safety and Health Act, other safety rules, organization standards and regulations, etc.
 - 4** Do not handle, pipe, or remove devices before confirming safety.
 - 1** Inspect and service the machine and devices after confirming safety of all systems related to this product.
 - 2** Note that there may be hot or charged sections even after operation is stopped.
 - 3** When inspecting or servicing the device, turn OFF the energy source (air supply or water supply), and turn OFF power to the facility. Discharge any compressed air from the system, and pay attention to possible water leakage and leakage of electricity.
 - 4** When starting or restarting a machine or device that incorporates pneumatic components, make sure that the system safety, such as pop-out prevention measures, is secured.
 - 5** Observe warnings and cautions in the following pages to prevent accidents.
- The precautions are ranked as "DANGER", "WARNING" and "CAUTION" in this section.

 **DANGER:** When a dangerous situation may occur if handling is mistaken leading to fatal or serious injuries, and when there is a high degree of emergency to a warning.

 **WARNING:** If handled incorrectly, a dangerous situation may occur, resulting in death or serious injury.

 **CAUTION:** When a dangerous situation may occur if handling is mistaken leading to minor injuries or physical damage.

Note that some items described as "CAUTION" may lead to serious results depending on the situation. Every item provides important information and must be observed.

Warranty

- 1** **Warranty period**
The product specified herein is warranted for one (1) year from the date of delivery to the location specified by the customer.
- 2** **Warranty coverage**
If the product specified herein fails for reasons attributable to CKD within the warranty period specified above, CKD will promptly provide a replacement for the faulty product or a part thereof or repair the faulty product at one of CKD's facilities free of charge. However, following failures are excluded from this warranty:
 - 1) Failure caused by handling or use of the product under conditions and in environments not conforming to those stated in the catalog, the Specifications, or the Instruction Manual.
 - 2) Failure caused by use of the product exceeding its durability (cycles, distance, time, etc.) or caused by consumable parts.
 - 3) Failure not caused by the product.
 - 4) Failure caused by use not intended for the product.
 - 5) Failure caused by modifications/alterations or repairs not carried out by CKD.
 - 6) Failure caused by reasons unforeseen at the level of technology available at the time of delivery.
 - 7) Failure caused by acts of nature and disasters beyond control of CKD.The warranty stated herein covers only the delivered product itself. Any loss or damage induced by failure of the delivered product is excluded from this warranty.
Note: For details on the durability and consumable parts, contact your nearest CKD sales office.
- 3** **Compatibility check**
The customer is responsible for confirming the compatibility of CKD products with the customer's systems, machines and equipment.



Pneumatic components

Safety Precautions

Be sure to read this section before use.

General precautions are General Catalog (No. CB-024SA) for details.

Product-specific cautions: Air booster ABP2 Series

Design/selection

⚠ WARNING

- Do not use the air booster for continuous operation such as in a compressor.

The Air Booster is a device for partial pressure increase in the factory. As with a compressor, its use in high frequency continuous operation will shorten its life. Use as a guideline 60 or less of the average operation cycle per minute. (Air boosters have a nominal life of 10 million cycles in normal use) Refer to page 2 for the estimated service life calculation.

⚠ CAUTION

- Do not use this product if vibration exceeds 50m/s^2 or impact exceeds 300m/s^2 .
- Pressure is raised by air pressure, so half of the air is discharged during boosting.
If the secondary side flow rate must be 1, the primary side requires a flow rate of $1 + 1 = 2$.

- Due to the cylinder structure inside, noise of 60 to 75dB (A) (primary side 0.5MPa → secondary side 0.95MPa, measurement distance 1 m) occurs during boosting.

*Noise when a silencer is installed.

- When the air booster is not used, stop the primary pressure. Stop unnecessary operation and prevent air consumption.

Mounting, installation and adjustment

⚠ WARNING

- Do not supply pressure exceeding 0.99 MPa onto the primary side.
- Check that set pressure does not exceed 0.99 MPa.

⚠ CAUTION

- Install a filter on the primary side to remove rust, foreign matter and drainage. The air booster compresses compressed air so drain is discharged easily from the secondary side. Installation of a filter is recommended to remove any moisture from the piping.
- Select a large pipe on the primary side to attain sufficient flow.
Recommended fittings : Effective cross-sectional area 30mm^2 or more, tube $\phi 12$ or more
- Install a silencer on the exhaust port of the air booster.
- Use piping with a stop valve at the air tank's drain port. Regularly discharge drain from the tank.

- There are no set regulations regarding the air booster's mounting orientation: it should optimally be horizontally installed on a flat surface.

- Install the air booster using 4-M6 depth 12 screw holes on the bottom or both sides. Only use these screw holes for installing the air booster.

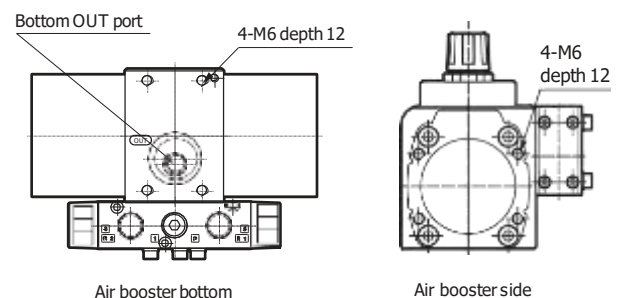

- The bolt used to install the air booster must not exceed the screw hole depth.
If you tighten the bolt forcibly, the screw hole could be damaged and air could leak.

ABP2-HP1 Series

- A foot bracket installed on both ends is available as an option.
(Model No.ABP2-02-B)
- Fix the air tank with the 4- ϕ 11 anchor bolt hole on the bottom.
- When connecting the air booster directly to the air tank, fix the tank mounting base to the air booster with the included hexagon socket head cap screw, attach the included O-ring to the tank mounting base using the bottom port, and fix the air tank top with the hexagon socket head cap screw.

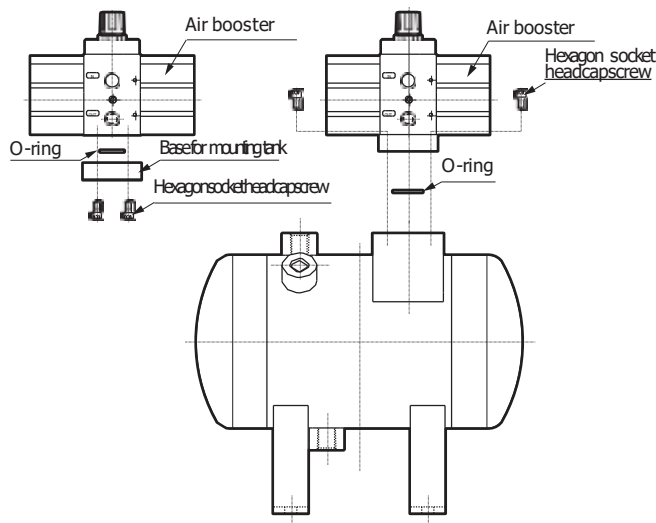

- Installation of an air tank and regulator after the air booster is recommended for attaining stable secondary pressure.

Use/maintenance

⚠ WARNING

- Stop the primary pressure and release the secondary pressure before maintenance, inspection, or repair of the air booster.

⚠ CAUTION

- When setting pressure, lift the pressure adjustment knob to release the lock, and then turn the pressure adjustment knob. Secondary pressure increases when the pressure adjustment knob is turned clockwise. The pressure adjustment knob must be locked after use.
- If primary pressure exceeds the set pressure due to fluctuations in pressure, etc., air is released from the pressure adjustment knob. Set a regulator on the primary side, and adjust the pressure at least 0.1 MPa lower from the set pressure.
- The silencer and pressure gauge are consumable parts and must be replaced regularly.

Related products

Linear Slide Hand LSH-HP Series

- **LSH-HP1 Series**
 - Increased linear guide performance
 - Increased flexibility in design
- **LSH-HP2 Series**
 - Long service life
 - Reduced processes on site
- **SL M-HP2 Series**
 - High precision: Repeatability $\pm 0.02\text{mm}$, linearity FS $\pm 0.5\%$
A high structure is realized by an integrated structure
 - with a displacement sensor built into the body
 - Environment-resistant IP65 equivalent amplifier and rubber cover

Catalog No.CC-1419A



HP Series General Catalog

- For high frequency use (HP1)
 - Optimized sliding technology for longer service life with the same dimensions as conventional products (more than 2-fold compared to conventional products)
- For dusty environments (G-HP1)
 - Rubber scraper and lube keeping structure improves durability in dusty environments (2x or more compared to conventional models)

Catalog No.CC-1421A

